

Gear ratio	L
4.4:1	17 mm [0.68 in]
9.7:1	17 mm [0.68 in]
20.4:1	19 mm [0.75 in]
34:1	21 mm [0.83 in]
47:1	21 mm [0.83 in]
75:1	23 mm [0.91 in]
99:1	23 mm [0.91 in]
172:1	25 mm [0.98 in]
227:1	25 mm [0.98 in]
378:1	27 mm [1.06 in]
499:1	27 mm [1.06 in]

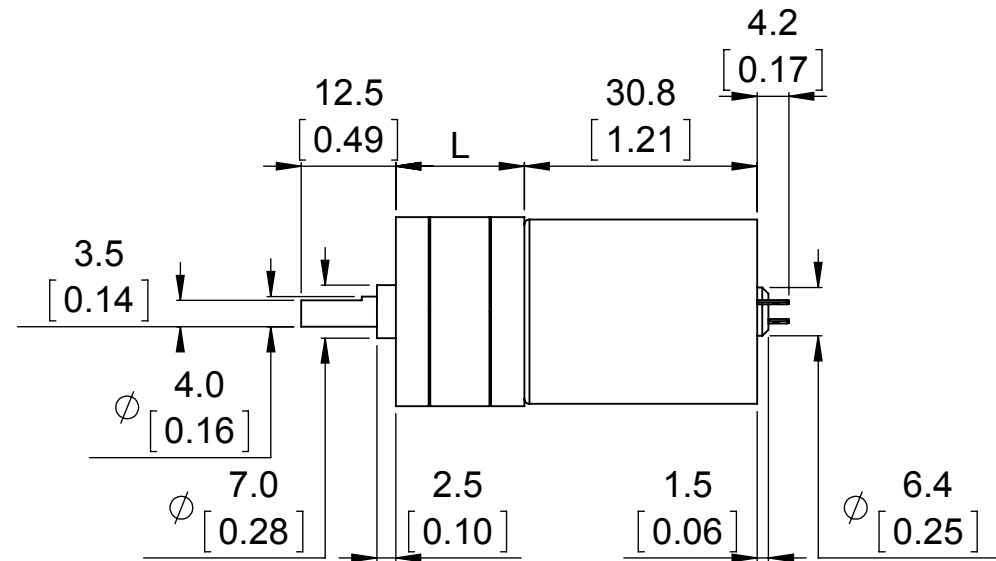
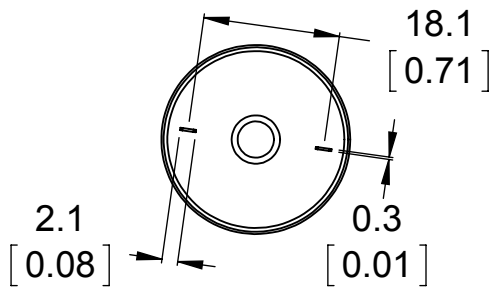
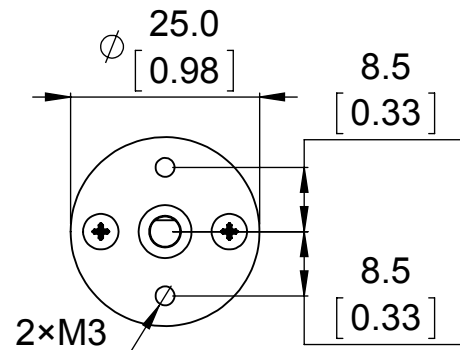
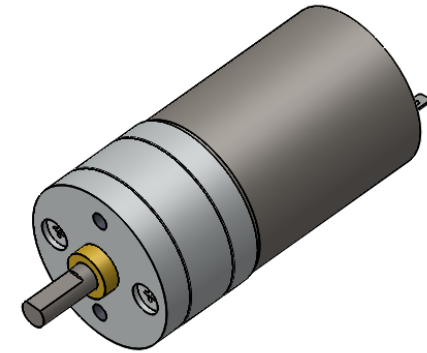

<https://www.pololu.com/category/115/25d-mm-gearmotors>

Name:
25D mm Metal Gearmotors (without encoders)

Drawing date:
15 January 2016

Units: mm
[in]

Material:
mix



Robotics & Electronics
© 2016 Pololu Corporation

1. To get the specified scale, select 100% in print settings.

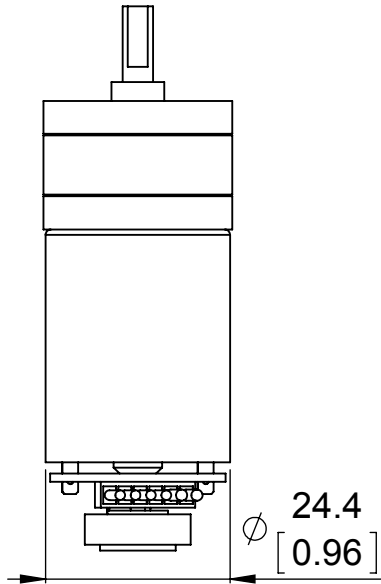
Scale: 1:1

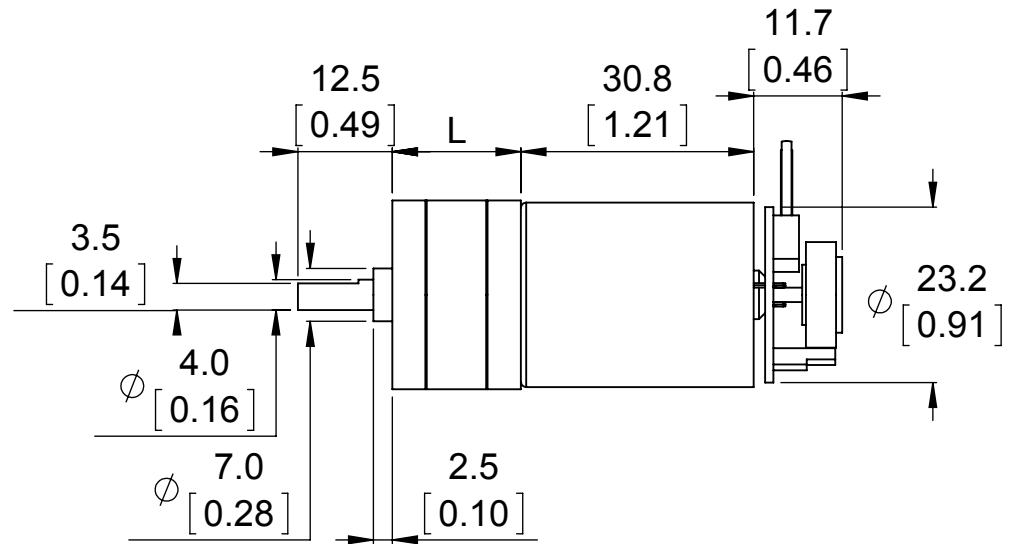
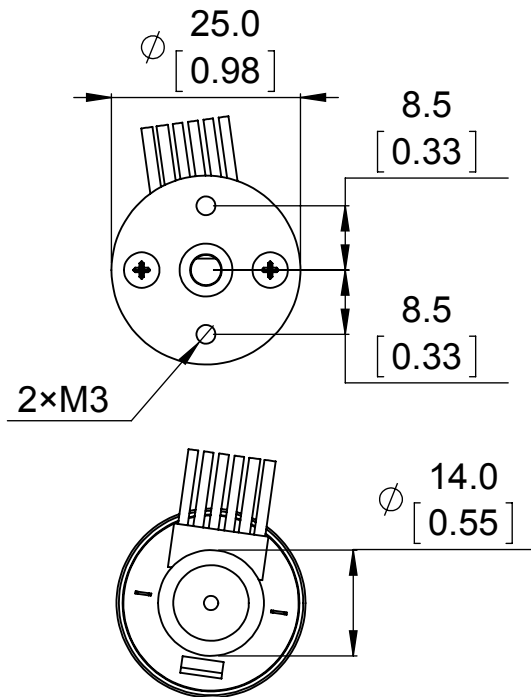
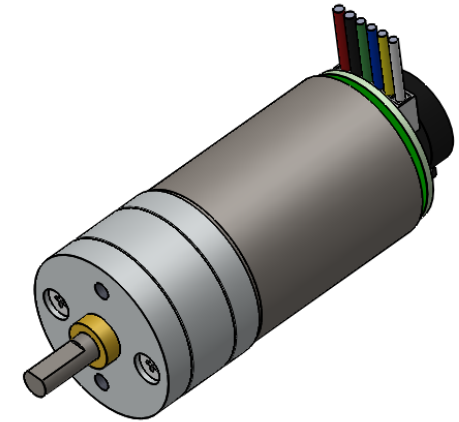

Gear ratio	L
4.4:1	17 mm [0.68 in]
9.7:1	17 mm [0.68 in]
20.4:1	19 mm [0.75 in]
34:1	21 mm [0.83 in]
47:1	21 mm [0.83 in]
75:1	23 mm [0.91 in]
99:1	23 mm [0.91 in]
172:1	25 mm [0.98 in]
227:1	25 mm [0.98 in]
378:1	27 mm [1.06 in]
499:1	27 mm [1.06 in]



<https://www.pololu.com/category/115/25d-mm-gearmotors>

Name:
25D mm Metal Gearmotors (with encoders)

Drawing date:
15 January 2016

Units: mm [in]

Material:
mix



1. To get the specified scale, select 100% in print settings.

Scale: 1:1