

1 Board dimensions (top view)
Scale 4:3

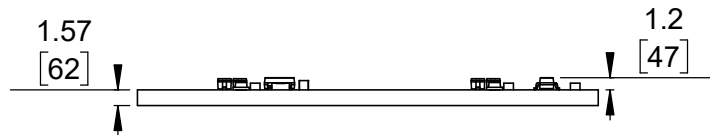

3 Long profile
Scale 4:3

- 1. Intended for #4 or M3 screws.
- 2. To get the specified scale, select 100% in print settings.
- 3. Drill location tolerance: ± 0.1 [± 5].
- 4. Board edge tolerance: ± 0.3 [± 10].

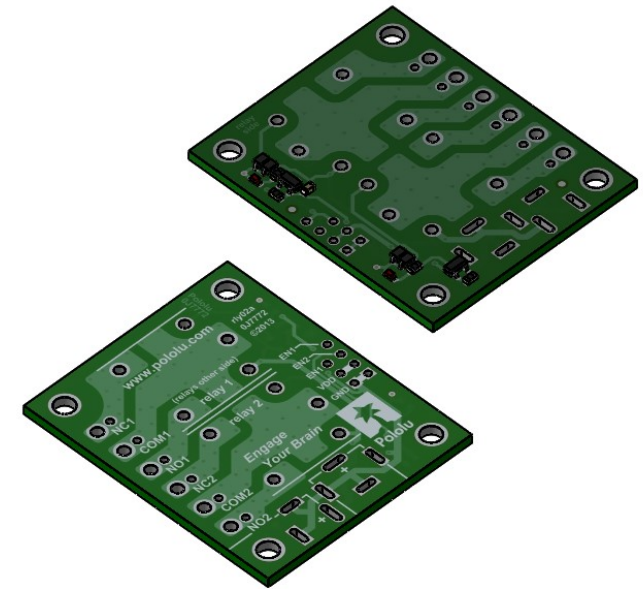

2 Isometric view
Scale 1:1

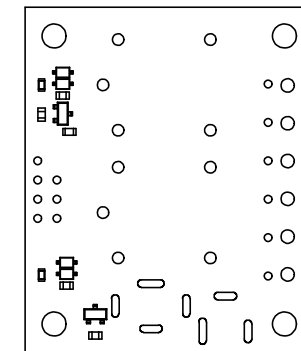

4 Top view (actual size)
Scale 1:1

<https://www.pololu.com/product/2484>

Name: Pololu Basic 2-Channel SPDT Relay Carrier for "Sugar Cube" Relays		Item number: 2484-2488
Drawing date: 9 February 2022	Dev code: rly02a	 © 2022 Pololu Corporation
Units: mm [mil]	Material: mixed	

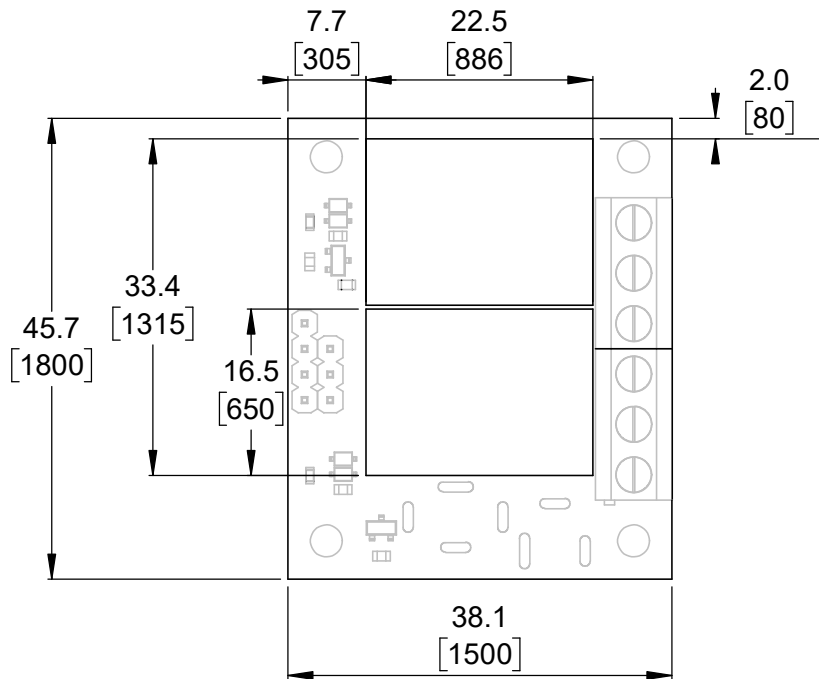

Board dimensions (top view)
(with included through-hole components)

1 Scale 4:3

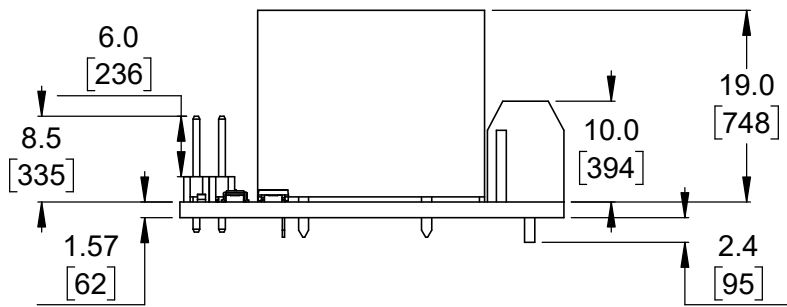

Short profile
(with included through-hole components)

3 Scale 4:3

1. To get the specified scale, select 100% in print settings.
2. Drill location tolerance: ± 0.1 [± 5].
3. Board edge tolerance: ± 0.3 [± 10].

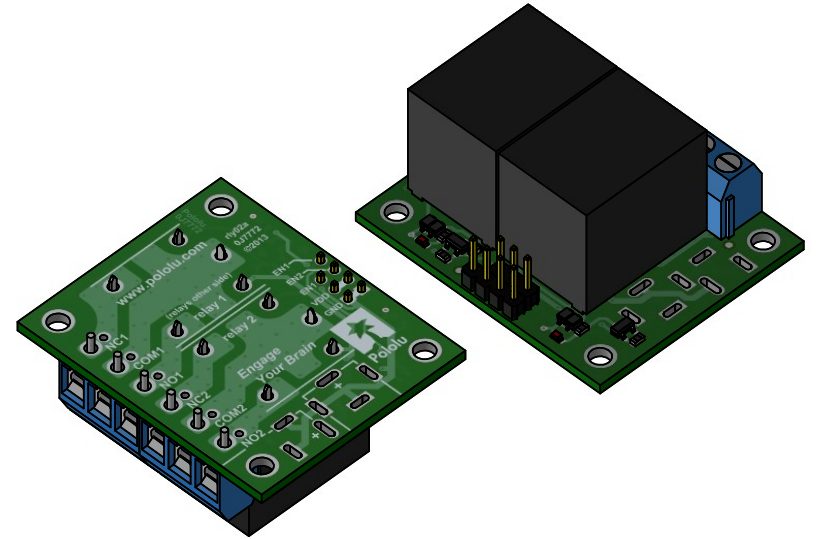

Isometric view
(with included through-hole components)

2 Scale 1:1

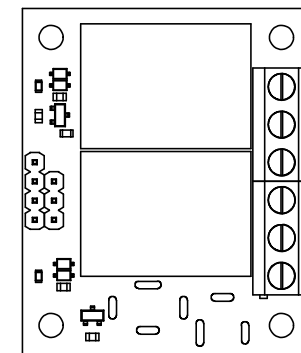

Top view (actual size)
(with included through-hole components)

4 Scale 1:1

<https://www.pololu.com/product/2485>

Name: Pololu Basic 2-Channel SPDT Relay Carrier with Relays		Item number: 2485-2488
Drawing date: 9 February 2022	Dev code: rly02a	 © 2022 Pololu Corporation
Units: mm [mil]	Material: mixed	

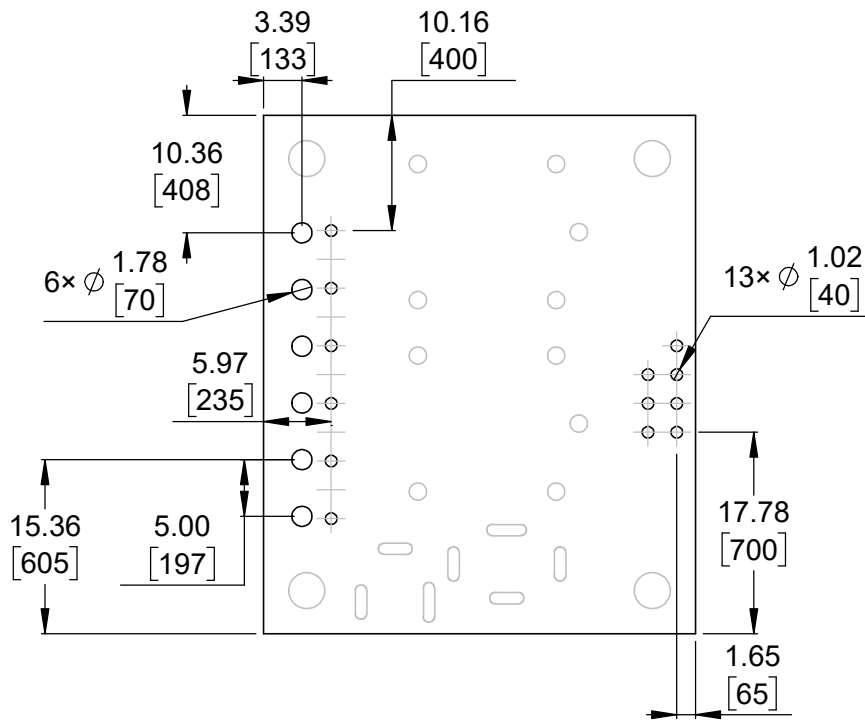

① Connector callouts (bottom view)
Scale 3:2

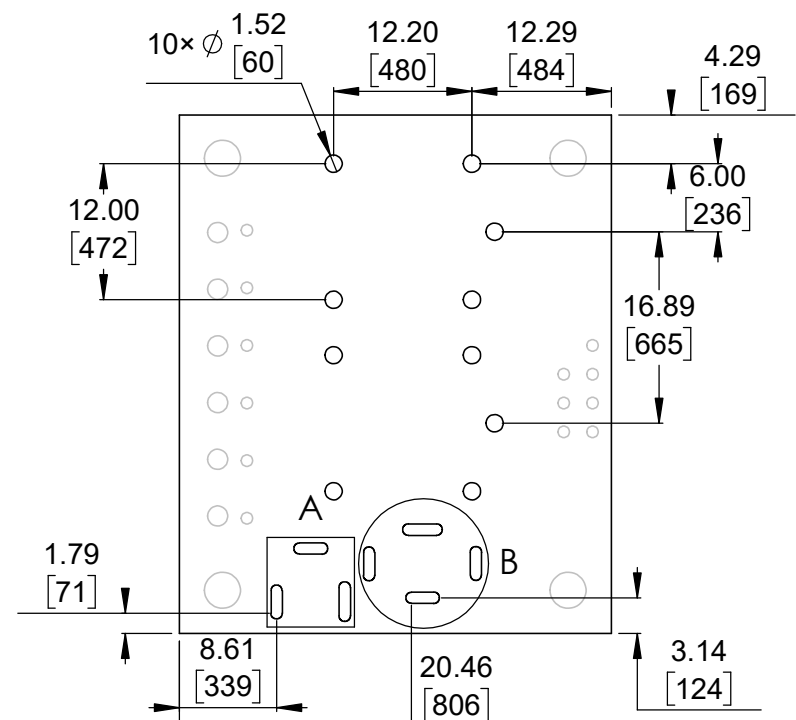

② Connector callouts (bottom view)
Scale 3:2

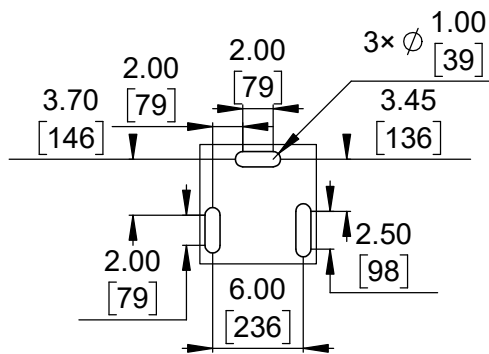

DETAIL A
SCALE 2 : 1

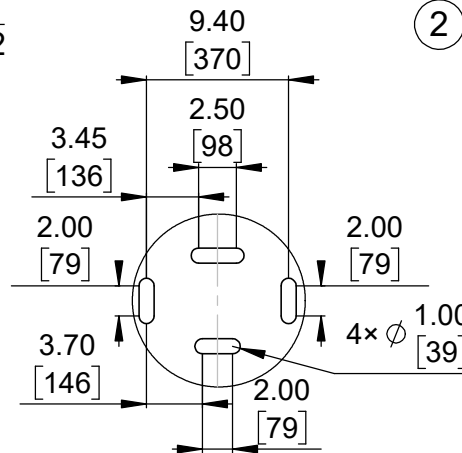

DETAIL B
SCALE 2 : 1

1. Grid lines indicate 2.54 mm [100 mil] spacing.
2. To get the specified scale, select 100% in print settings.
3. Drill location tolerance: ± 0.1 [± 5].
4. Board edge tolerance: ± 0.3 [± 10].

<https://www.pololu.com/product/2484>

Name: Pololu Basic 2-Channel SPDT Relay Carrier for "Sugar Cube" Relays		Item number: 2484-2488
Drawing date: 9 February 2022	Dev code: rly02a	 © 2022 Pololu Corporation
Units: mm [mil]	Material: mixed	