



# BASIC MICRO

TECHNOLOGY AT WORK

**B0099 - Robo Claw 2 Channel 5A Motor Controller  
Data Sheet**

### Feature Overview:

- 2 Channel at 5A, Peak 7A
- Hobby RC Radio Compatible
- Serial Mode
- TTL Input
- Analog Mode
- 2 Channel Quadrature Decoding
- Thermal Protection
- Lithium Cut Off
- Battery Elimination Circuit (BEC)
- Packet Serial
- High Speed Direction Switching
- Flip Over Switch
- Over Current Protection
- Regenerative Braking

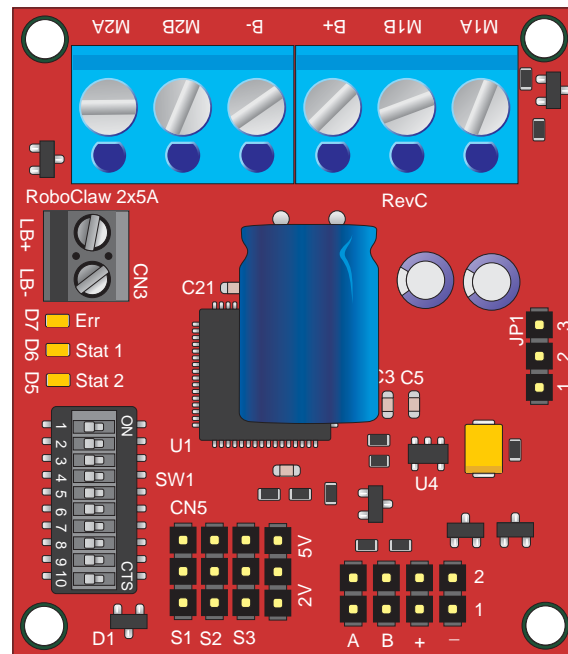

### Basic Description

The Robo Claw 2X5 Amp is an extremely efficient, versatile, dual channel synchronous regenerative motor controller. It supports dual quadrature encoders and can supply two brushed DC motors with 5 Amps continuous and 7 Amp peak.

With dual quadrature decoding you get greater control over speed and velocity. Automatically maintain a speed even if the load increases. Robo Claw also has a built in PID routine for use with an external control system.

Robo Claw is easy to control with several built in modes. It can be controlled from a standard RC receiver/transmitter, serial device, microcontroller or an analog source, such as a potentiometer based joystick. Robo Claw is equipped with screw terminal for fast connect and disconnect. All modes are set by the onboard dip switches making setup a snap!

### Optical Encoders

Robo Claw features dual channel quadrature decoding. Robo Claw gives you the ability to create a closed loop system. Accurately know a motors speed and direction giving you greater control over DC motors systems.

### Power System

The Robo Claw is equipped with synchronous regenerative motor drivers. This means your battery is recharged when slowing down, braking or reversing. Also included is a 5VDC battery eliminator circuit (BEC). The BEC can supply a useful current of around 100mA at certain input voltages. The BEC is meant to provide power to your microcontroller or RC receiver.

Hardware Overview:

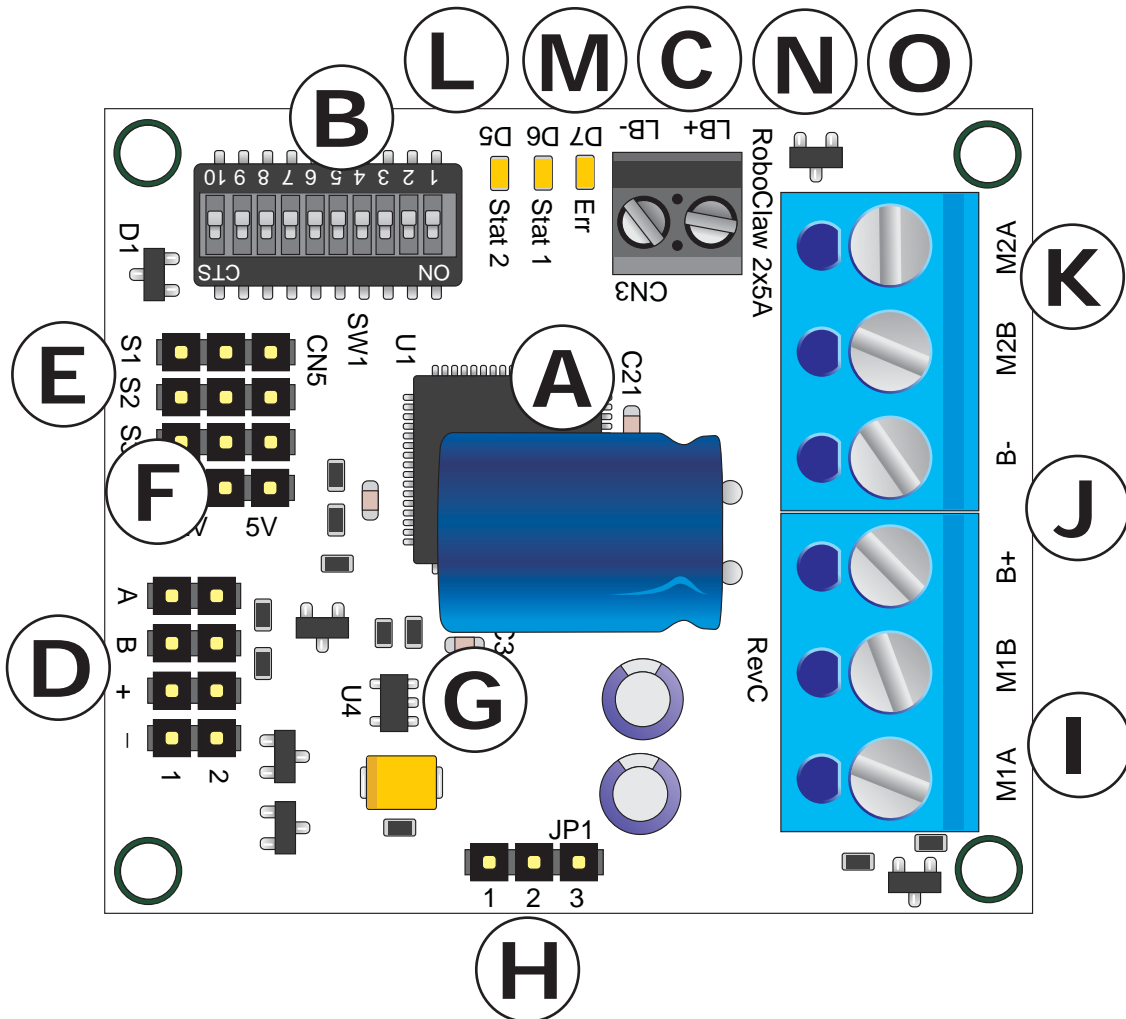

- A:** Microcontroller
- B:** DIP Switch
- C:** Logic Battery 3.5mm Screw Terminals
- D:** Encoder Input Header
- E:** Input Control Headers
- F:** VCC on Input Control Header Disable Jumper
- G:** Logic Voltage Regulator
- H:** Logic Voltage Source Selection Header
- I:** DC Motor Channel 2 Screw Terminals
- J:** Main Battery Input Screw Terminals
- K:** DC Motor Channel 1 Screw Terminals
- L:** Status LEDs
- M:** Error LED

Dimensions:

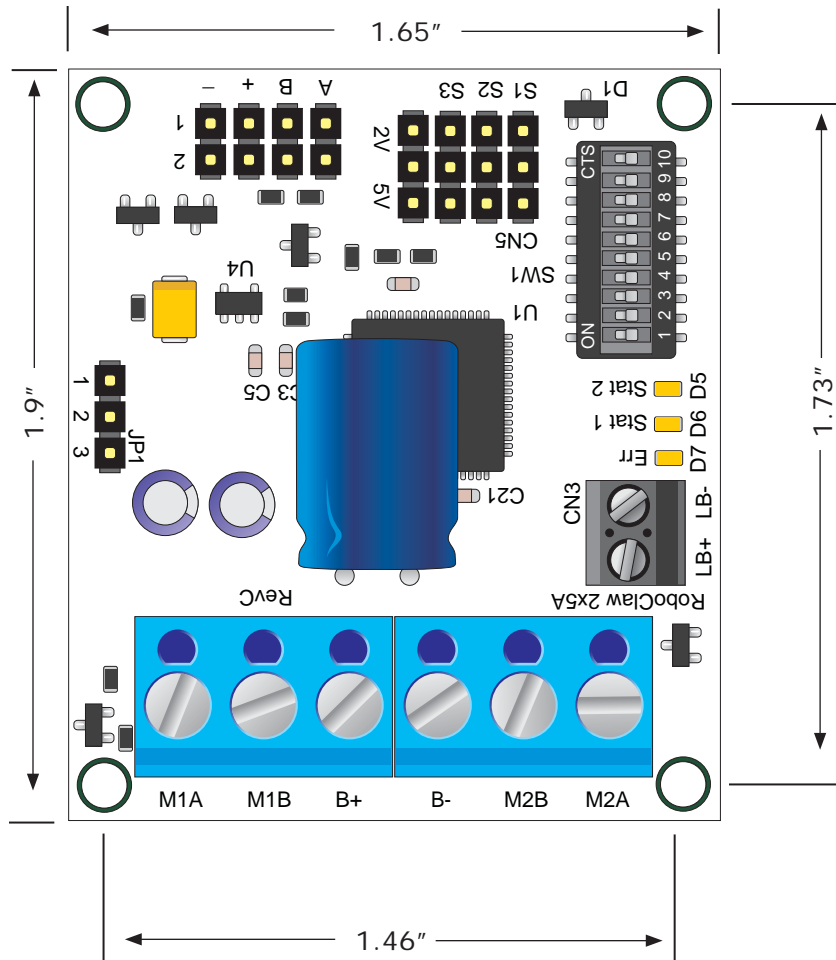

**Board Edge:** 1.9"W X 1.65"L

**Hole Pattern:** 0.100D, 1.46"W x 1.73"H

Header Overview

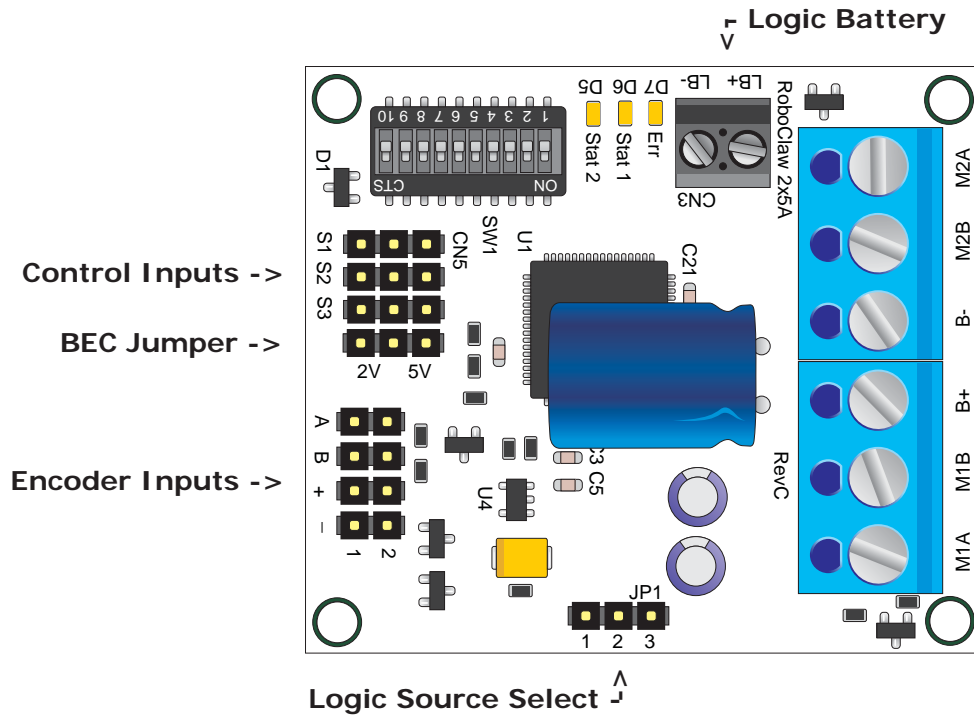

Logic Battery Screw Terminals

The logic circuits can be powered from the main battery or a secondary battery wired to CN3. In many situations the load on the main battery may be too high to keep the logic circuit supplied properly in this situation a second battery is utilized. JP1 controls what source powers the logic circuits. The maximum input voltage for the logic supply is 17VDC. If the main power source is over 17VDC a second lower voltage source must be used to supply the logic power.

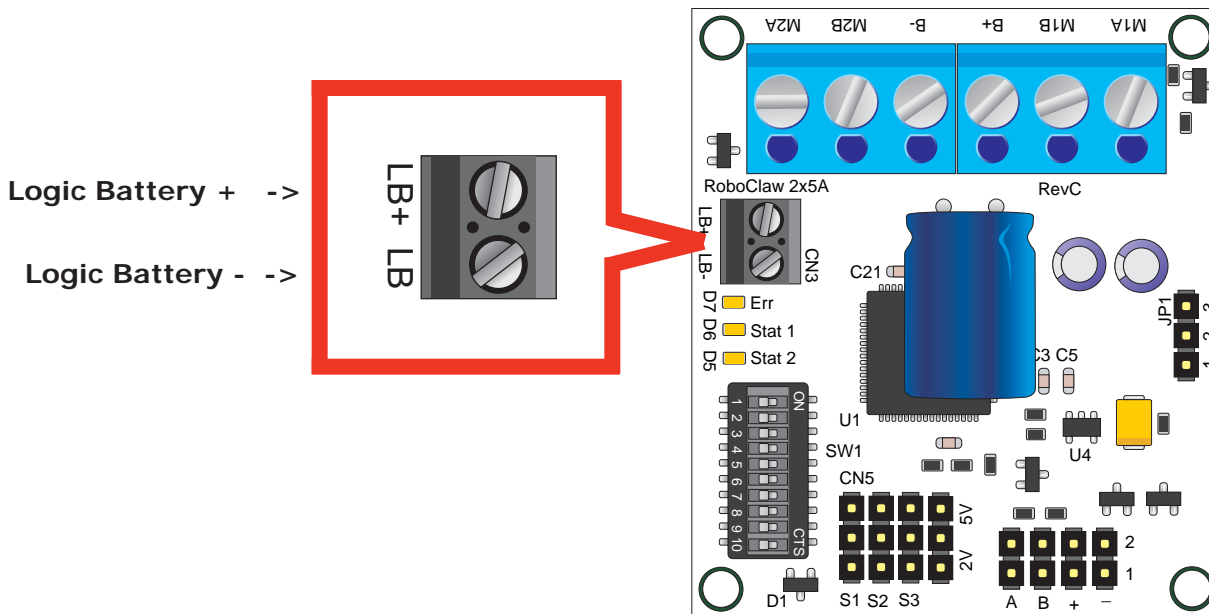

**Encoder Inputs**

This header is setup for dual quadrature encoders. A and B are the inputs from the encoders. The header also supplies 5VDC to power the encoders. When connecting the encoder make sure the leading channel for the direction of rotation is connected to A. If one encoder is backwards to the other you will have one internal counter counting up and the other counting down. Which will affect the operation of Robo Claw. Refer to the data sheet of the encoder you are using for channel direction.

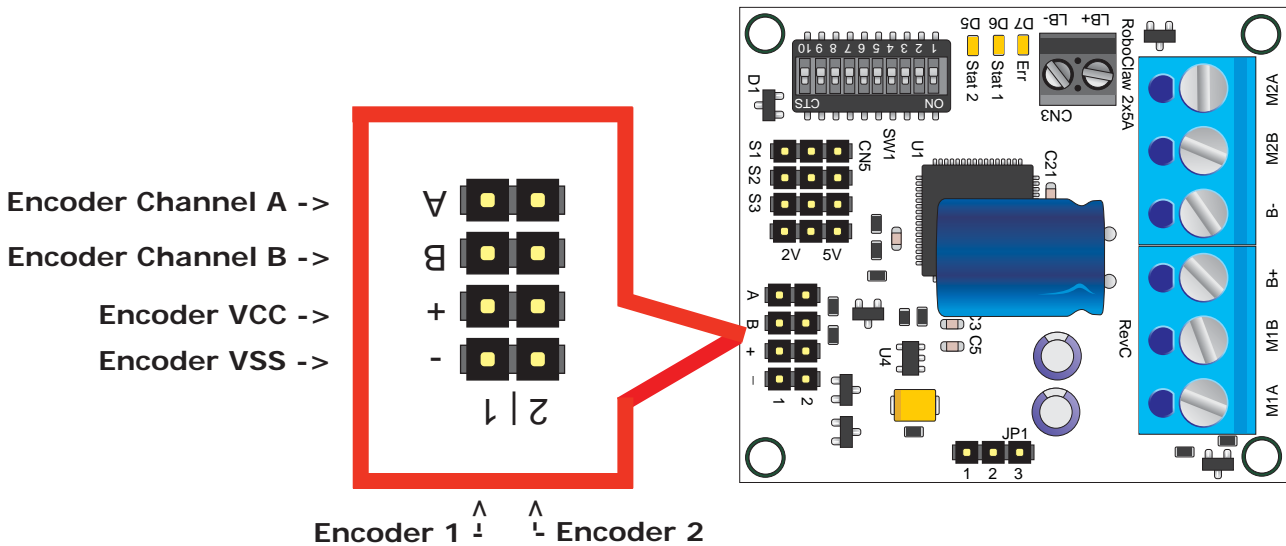

**Control Inputs**

S1, S2 and S3 are setup for standard servo style headers GND, +5V and I/O. S1 and S2 are the control inputs for serial, analog and RC modes. S3 is only used as the flip switch input and is only active in RC and Analog modes.

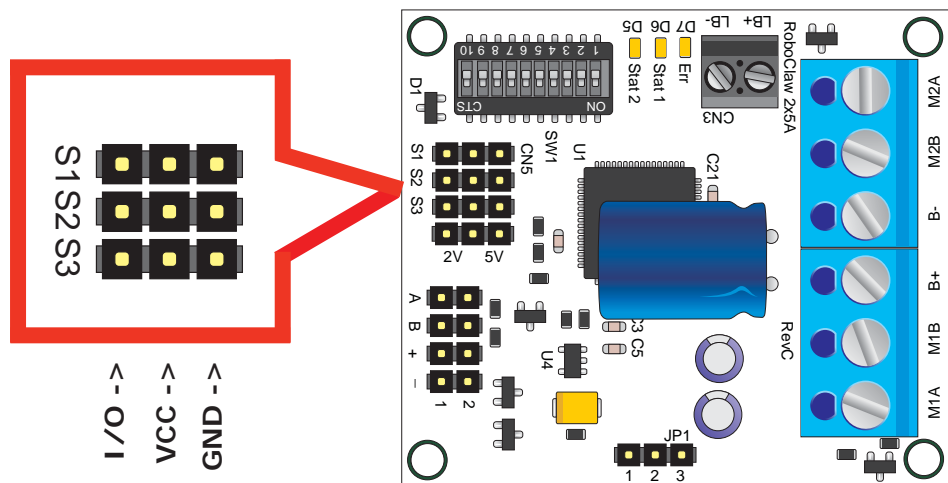

**BEC Jumper**

VCC on control input headers S1,S2 and S3 can be turned off or on by the jumper JP3. When BEC jumper is installed 5VDC is supplied from the logic supply to the center pin of the 3 pin headers. In some systems the RC receiver may have its own supply and will conflict with the Robo Claw logic supply. Removing the BEC jumper disables VCC on S1, S2 and S3 headers.

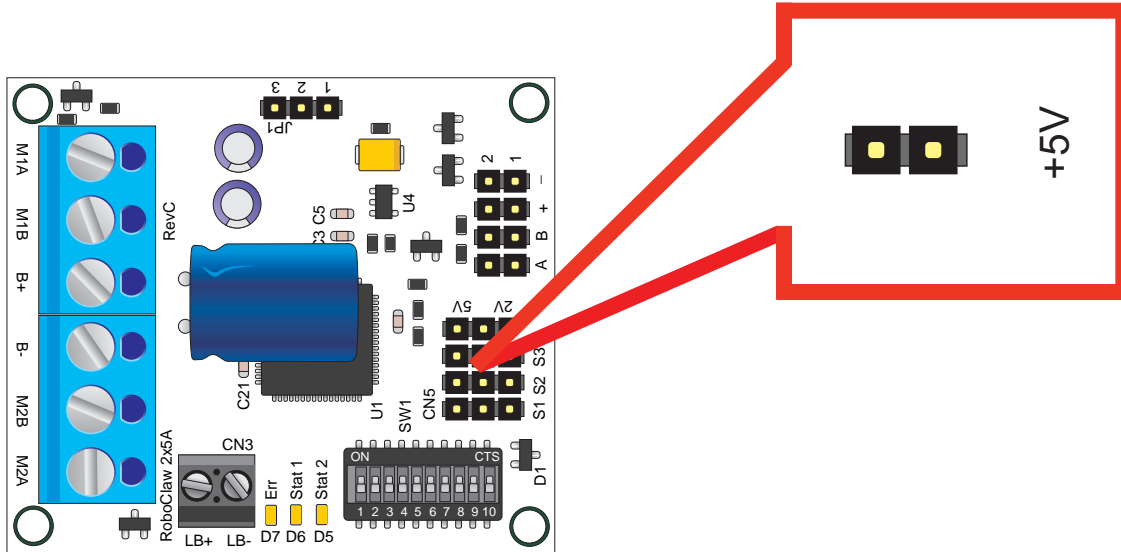

**Logic Supply Select**

The Robo Claw logic requires 5VDC which is provided from the on board regulator. The regulator source voltage is set with the logic supply jumper. Pins 1-2 = Logic Battery, 2-3 = Main Battery. JP1 label is shown upside down to match the orientation on the Robo Claw.

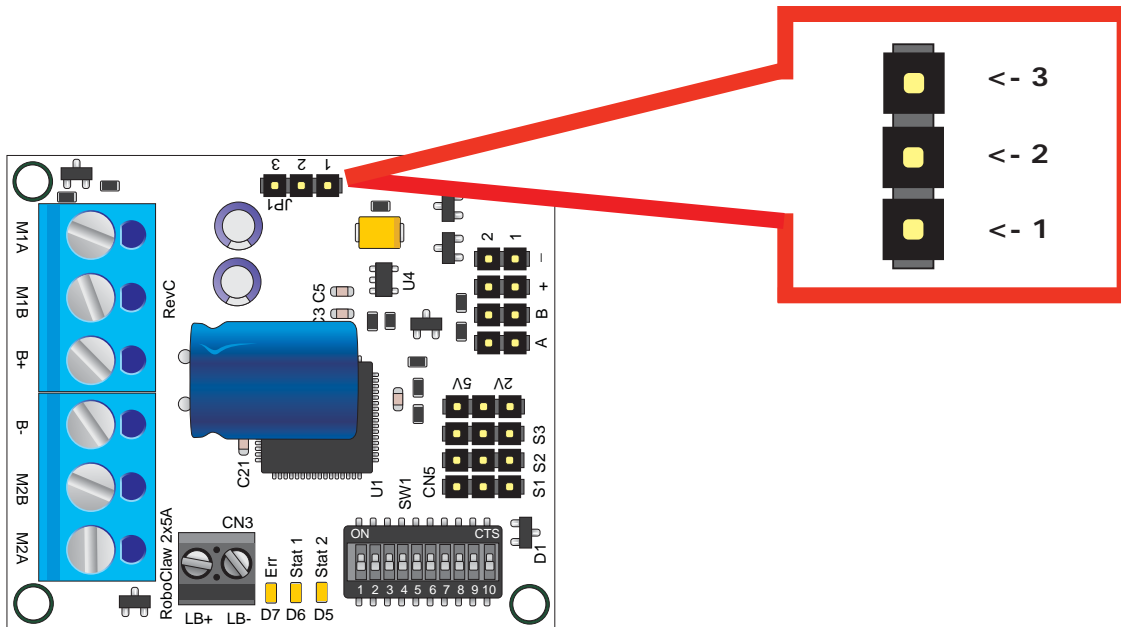

### Main Battery Screw Terminals

The main battery connections are marked with a B- and B+ on the main screw terminal. B+ is the positive side of the battery typically marked with a red wire. The B- is the negative side of the battery and typically marked with a black wire. When connecting the main battery its a good practice to use a switch to turn the main power on and off. When placing a switch in between the Robo Claw and main battery you must use a switch with the proper current rating. Since the Robo Claw can draw up to 7A peak you should use a switch rated for at least 10A. The main battery can be 6V to 17V DC.

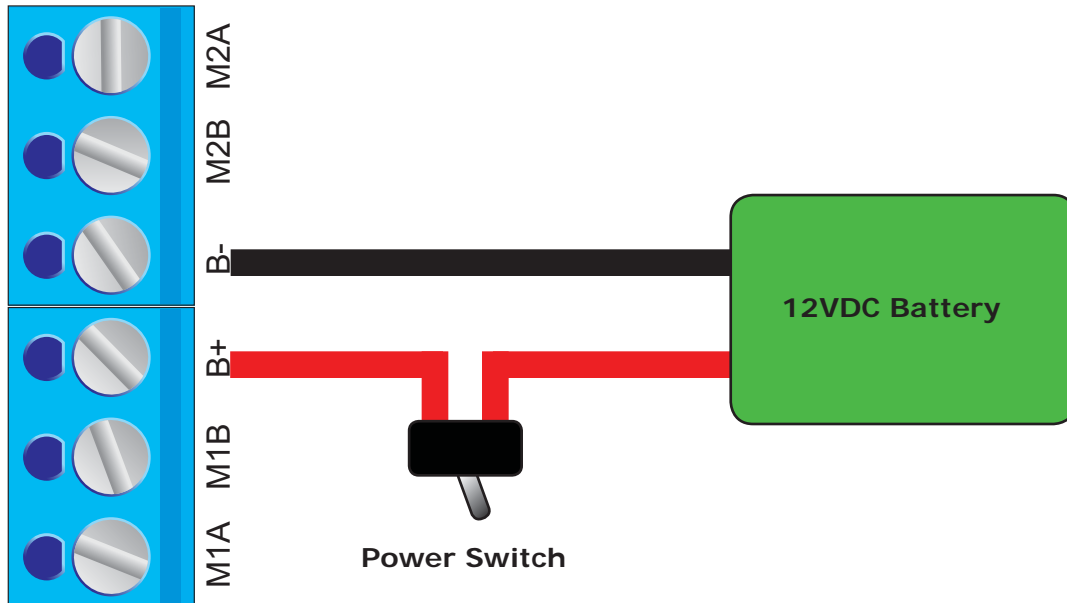

### Motor Screw Terminals

The motor screw terminals are marked with M1A / M1B for channel 1 and M2A / M2B for channel 2. There is no specific polarities for the motors. However if you want both motors turning in the same direction on a 4 wheeled robot you need to reverse one of the motors as shown below:

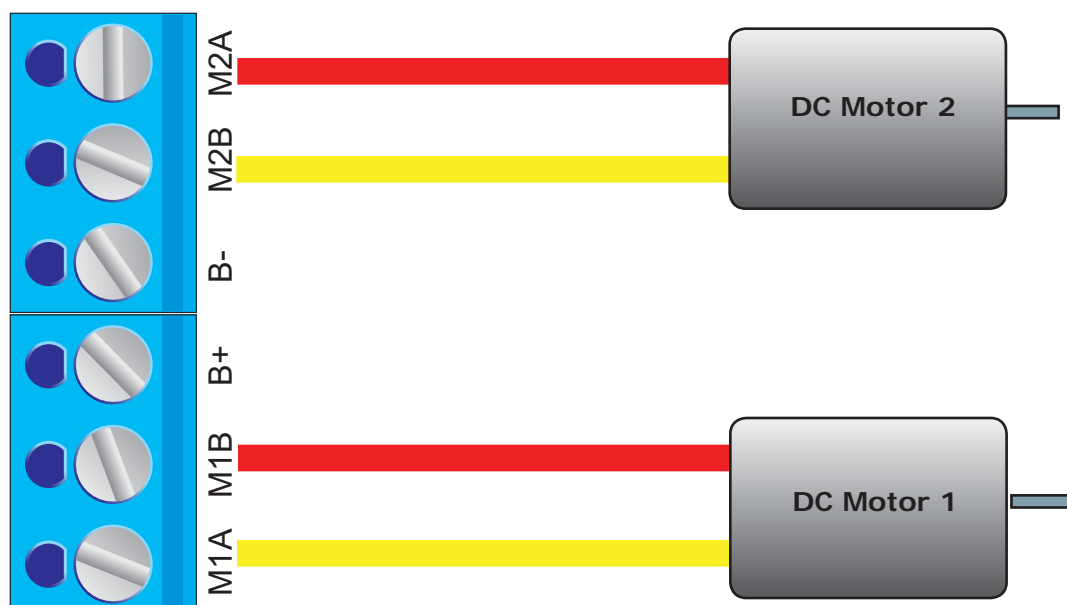



### Status and Error LEDs

The Robo Claw has 3 main LEDs. 2 Status LEDs and 1 Error LED. When Robo Claw is first powered up all 3 LED should blink several times briefly to indicate all 3 LEDs are functional. The 2 status LEDs function differently depending on the mode that is set.

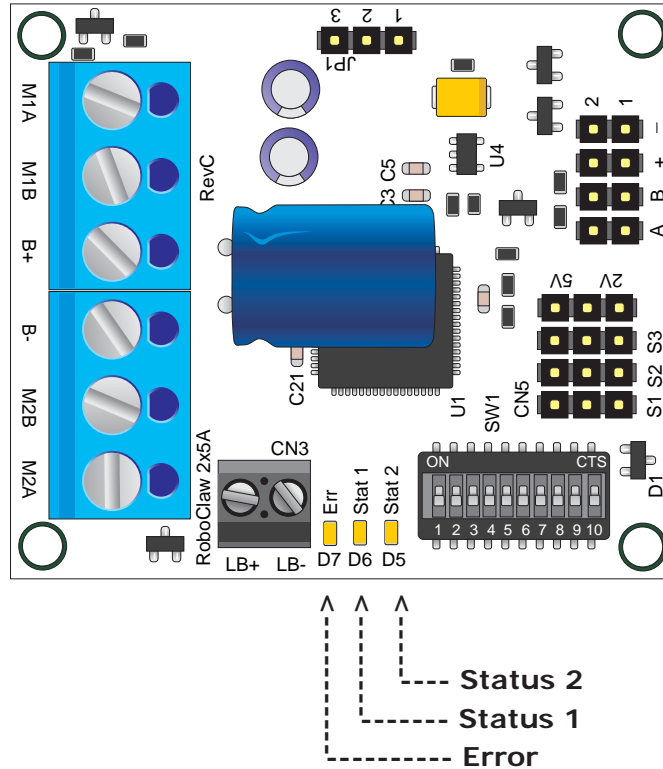

### Analog Mode

Status LED 1 = On continuous.  
 Status LED 2 = On when motor(s) active.

### RC Mode

Status LED 1 = On continuous, blink when pulse received.  
 Status LED 2 = On when motor(s) active.

### Serial Modes

Status LED 1 = On continuous, blink on serial receive.  
 Status LED 2 = On when motor(s) active.

### Errors - Error LED

Over Current	= On continuous.
Over Heat	= Fast blinking (.075 second intervals).
Main Batt Low	= Half second blinking intervals.
Main Batt High	= Flicker blinking (1 second on, .3 seconds off).
Logic Batt Low	= Steady blinking (.5 second on, .5 second off).
Logic Batt High	= Steady blinking (.5 second on, .5 second off).
Quad Decoder Fail	= Error LED and Status LED 2 alternate blink on start up.

**DIP Switch Overview**

The dip switch on Robo Claw is used to set its operating modes and the many options. The switch is marked with an ON label at its top. The switches are also labeled from left to right starting with switch 1 and ending with switch 10. When a dip switch is moved toward the label ON it is considered ON. When the switch is facing away from the ON label it is considered off. Be careful to ensure the switch is not floating in between and is firmly OFF or ON. See illustration below. The red switch (SW1) is in the ON position. The grey colored switches are in the OFF position.

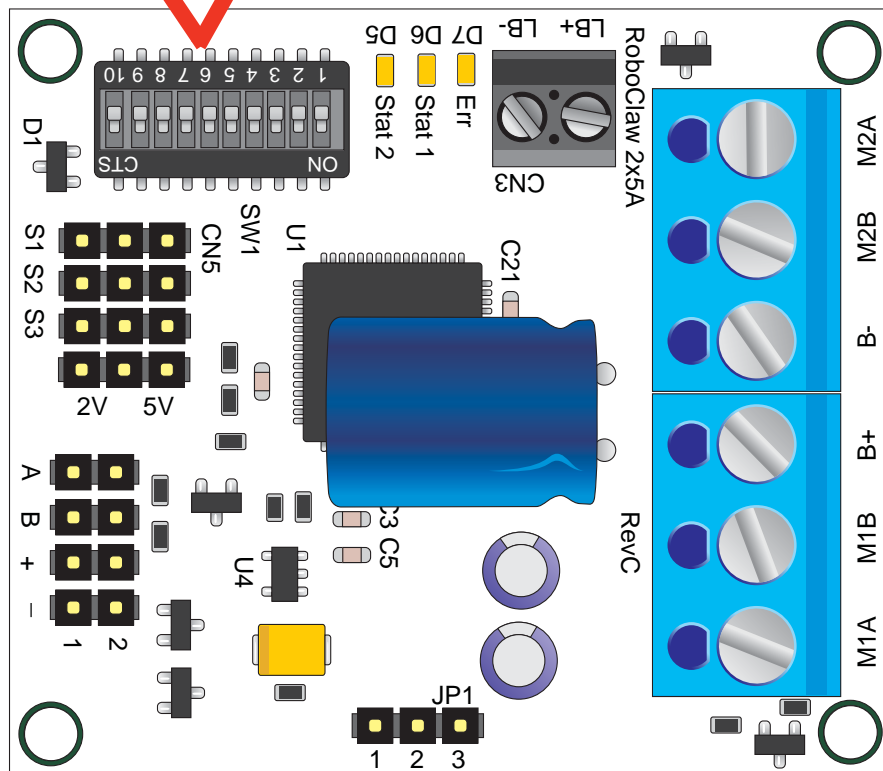
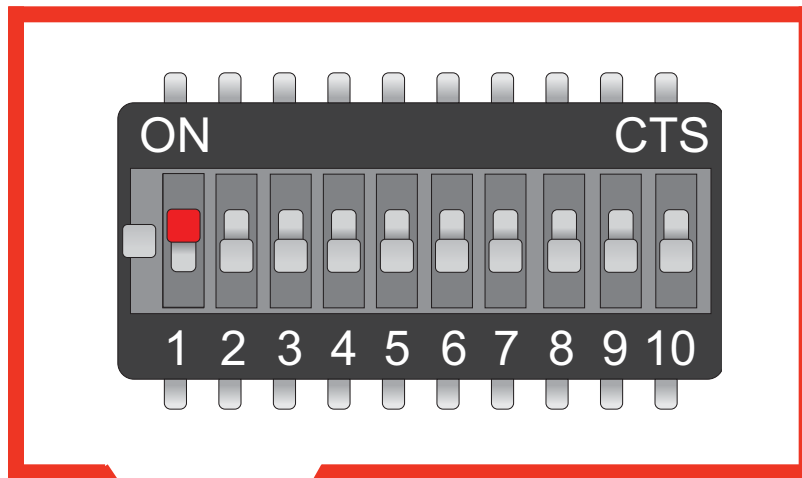

**Low Voltage Cutoff**

Robo Claw has a built in low voltage protection. This has two main purposes. To protect Robo Claw from running erratically when the main battery level gets to low and protect a Lithium battery from being damaged.

Voltage	SW8	SW9	SW10
Not Monitored	OFF	OFF	OFF
Lead Acid - Auto	ON	OFF	OFF
2- Cell (6V Cutoff)	OFF	ON	OFF
3- Cell (9V Cutoff)	ON	ON	OFF
4- Cell (12V Cutoff)	OFF	OFF	ON
5- Cell (15V Cutoff)	ON	OFF	ON
6- Cell (18V Cutoff)	OFF	ON	ON
7- Cell (21V Cutoff)	ON	ON	ON

## Robo Claw Modes

There are 4 modes. Each with a specific way to control Robo Claw. The following list explain each mode and the ideal application.

### Mode 1 - RC Input

With RC input mode Robo Claw can be controlled from any hobby RC radio system. RC input mode also allows low powered microcontroller such as a Basic Stamp or Nano to control Robo Claw. Robo Claw expects servo pulse inputs to control the direction and speed. Very similar to how a regular servo is controlled. RC mode can not use encoders.

### Mode 2 - Analog

Analog mode uses an analog signal from 0V to 5V to control the speed and direction of each motor. Robo Claw can be controlled using a potentiometer or filtered PWM from a microcontroller. Analog mode is ideal for interfacing Robo Claw joystick positioning systems or other non microcontroller interfacing hardware. Analog mode can not use encoders.

### Mode 3 - Simple Serial

In simple serial mode Robo Claw expects TTL level RS-232 serial data to control direction and speed of each motor. Simple serial is typically used to control Robo Claw from a microcontroller or PC. If using a PC a MAX232 type circuit must be used since Robo Claw only works with TTL level input. Simple serial includes a slave select mode which allows multiple Robo Claws to be controlled from a signal RS-232 port (PC or microcontroller). Simple serial is a one way format, Robo Claw only receives data.

### Mode 4 - Packet Serial

In packet serial mode Robo Claw expects TTL level RS-232 serial data to control direction and speed of each motor. Packet serial is typically used to control Robo Claw from a microcontroller or PC. If using a PC a MAX232 type circuit must be used since Robo Claw only works with TTL level input. In packet serial mode each Robo Claw is assigned an address using the dip switches. There are 8 addresses available. This means up to 8 Robo Claws can be on the same serial port. When using the quadrature decoding feature of Robo Claw packet serial is required since it is a two way communications format. This allows Robo Claw to transmit information about the encoders position and speed.

# RC Input

### Mode 1 - RC Input

For RC mode set SW1 = ON. RC mode is typically used when controlling Robo Claw from a hobby RC radio. This mode can also be used to simplify driving Robo Claw from a microcontroller using servo pulses. There are 4 options in RC Input mode. These options are set with SW4, SW5, SW6 and SW7.

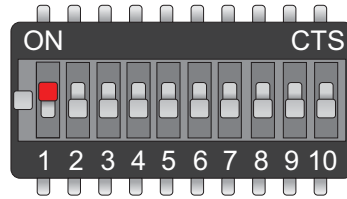

### Switch 4 - Mixing Mode

SW4 = ON: Turns mixing mode ON. S1 controls forward and reverse. S2 controls steering. Control will be like a car.

SW4 = OFF: Turns mixing mode OFF. S1 controls motor 1 speed and direction. S2 controls motor 2 speed and direction. Control will be like a tank.

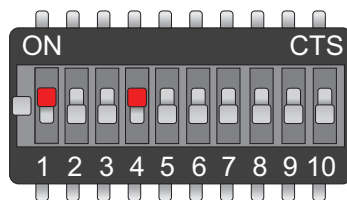

### Switch 5 - Exponential Mode

SW5 = ON: Turns exponential mode ON. Exponential response softens the center control position. This mode is ideal with tank style robots.

SW5 = OFF: Turns exponential mode OFF. Motor response will be linear and directly proportional to the control input. Ideal for 4 wheel style robots.

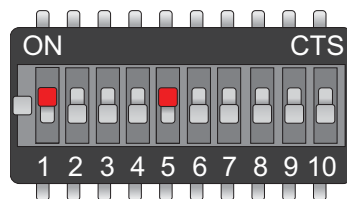

**Switch 6 - MCU or RC Control**

SW6 = ON: Turns MCU control mode ON. Robo Claw will continue to execute last pulse received until new pulse received. Signal lost fail safe and auto calibration are off in this mode.

SW6 = OFF: Turns RC control mode ON. Robo Claw will calibrate the center and end points automatically to maximize stick throw. This mode includes a fail safe. If control input is lost, Robo Claw will shut down.

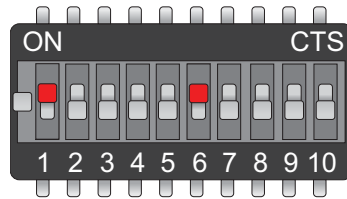
**Switch 7 - Flip Switch Input**

SW7 = ON: Flip switch input requires servo pulse. Pulse greater than 1.5ms will reverse steering control. The flip switch is typically used in robot combats to automatically reverse the controls if a robot is flipped over.

SW7 = OFF: Flip switch input expects TTL control signal. 0V for flipped and 5V for normal.

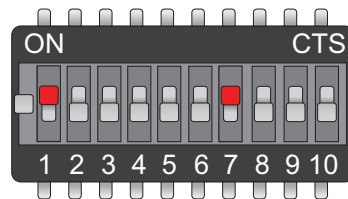

**Servo Pulse Ranges**

The Robo Claw expects RC servo pulses on S1 and S2 to drive the motors when the dip switches are set for RC mode. The center points are calibrated at start up. 1000us is the default for full reverse and 2000us is the default for full forward. The Robo Claw will auto calibrate these ranges on the fly. If a pulse smaller than 1000us or larger than 2000us is detected the new pulses will be set as the new range.

Pulse	Function
1000us	Full Reverse
2000us	Full Forward



**RC Wiring Example**

Connect the Robo Claw as shown below. Set switches SW1 and SW4 to ON. Make sure you center the control sticks and turn the radio on first, then the receiver, then Robo Claw. It will take Robo Claw about 1 second to calibrate the neutral position.

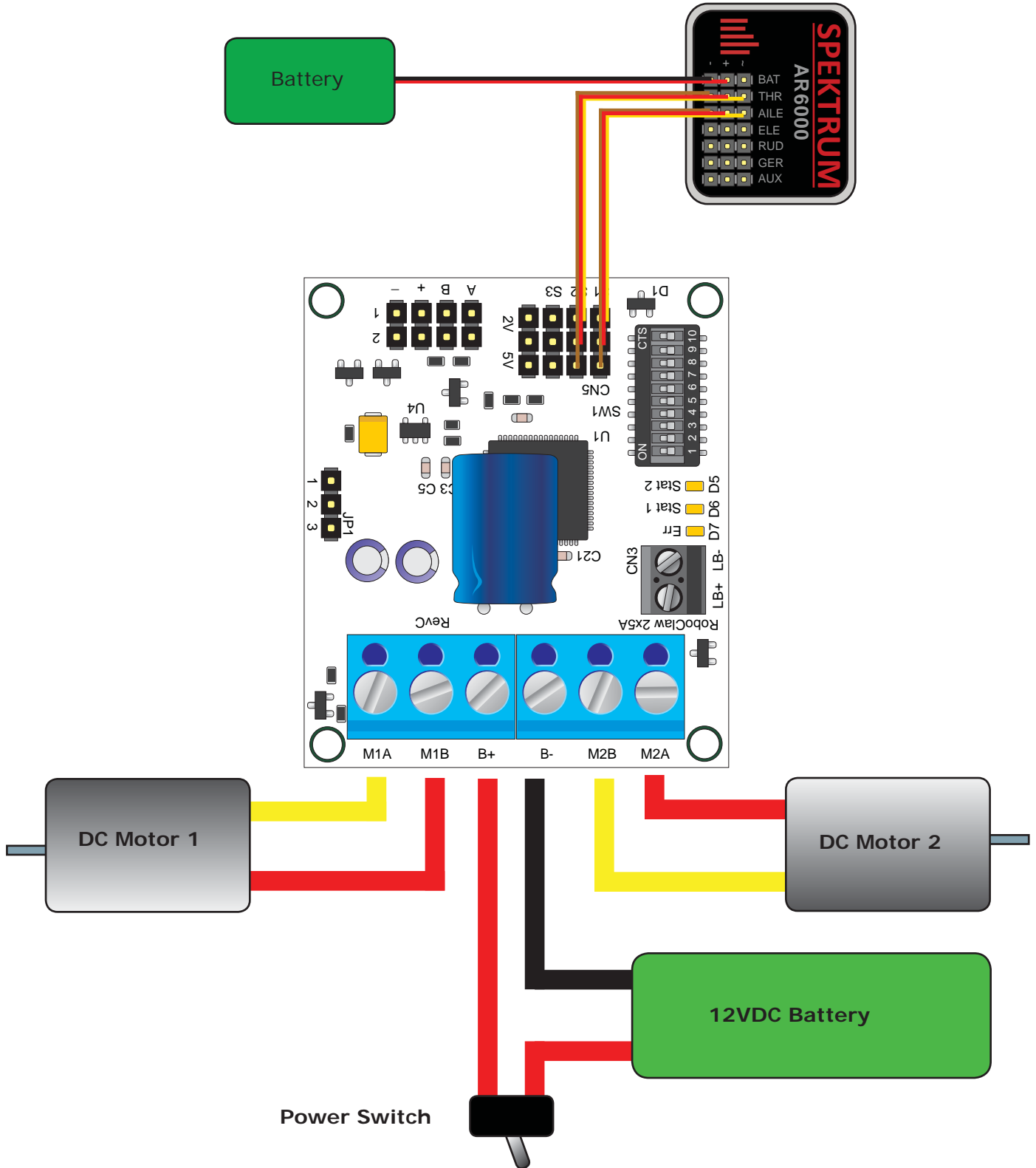

### RC Control From MCU Example

The example will drive a 2 motor robot (Lynxmotion 4Wheel) in reverse, stop, forward, left turn and then right turn. The program was written and tested with a BasicATOM Pro and P0 connected to S1, P1 connected to S2. Set switches SW1, SW4, SW5 and SW6 to ON.

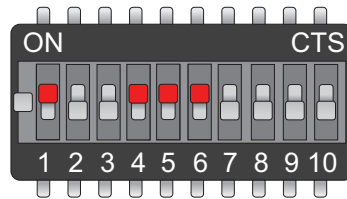

```
;Basic Micro Robo Claw RC Mode. Control Robo Claw
;with servo pulses from a microcontroller.
;Switch settings: SW1=ON, SW4=ON, SW5=ON and SW6=ON
```

```
Main
```

```
  pulsout P15,(1500*2)    ; stop
  pulsout P14,(1500*2)    ; stop
  pause 2000

  pulsout P15,(500*2)     ; full backward
  pause 1000

  pulsout P15,(1500*2)    ; stop
  pause 2000

  pulsout P15,(2500*2)    ; full forward
  pause 1000

  pulsout P15,(1500*2)    ; stop
  pause 2000

  pulsout P14,(500*2)     ; left turn
  pause 1000

  pulsout P14,(1500*2)    ; stop
  pause 2000

  pulsout P14,(2500*2)    ; right turn
  pause 1000
```

```
goto main
```

# Analog Input

### Mode 2 - Analog Input

For Analog mode set SW1, SW2 and SW3 = OFF. In this mode S1 and S2 are set as analog inputs. Voltages of 0V = Full reverse, 2.5V = Stop and 5V = Full forward. You can use linear potentiometers of 1K to 100K to control Robo Claw. Or you can use a PWM signal to control Robo Claw in analog mode. If using a PWM signal to control Robo Claw you will need a simple filter circuit to clean up the pulse.

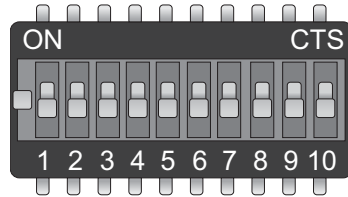

### Switch 4 - Mixing Mode

SW4 = ON: Turns mixing mode ON. One channel input to control forward and reverse. Second channel input for steering control. Control will be like a car.

SW4 = OFF: Turns mixing mode OFF. One channel controls one motor speed and direction. Second channel controls the other motor speed and direction. Control will be like a tank.

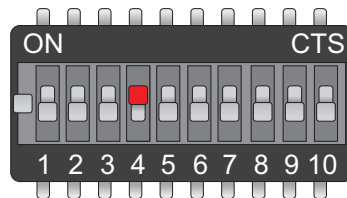

### Switch 5 - Exponential Mode

SW5 = ON: Turns exponential mode ON. Exponential response softens the center control position. This mode is ideal with tank style robots.

SW5 = OFF: Turns exponential mode OFF. Motor response will be linear and directly proportional to the control input. Ideal for 4 wheel style robots.

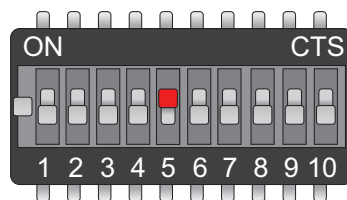

**Switch 6 - 4x Sensitivity**

SW6 = ON: Turns 4x sensitivity ON. With this option the Robo Claw input control voltages are now more sensitive. Voltage of 1.875V = Full reverse, 2.5V = Stop and 3.125V = Full forward. This option can also be used to drive Robo Claw from a 3.3v microcontroller.

SW6 = OFF: Turns 4x sensitivity OFF. Normal analog voltages apply. Voltages of 0V = Full reverse, 2.5V = Stop and 5V = Full forward.

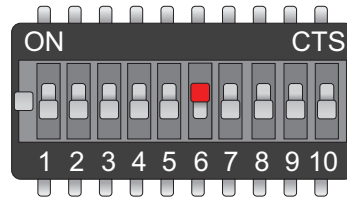

**Analog Wiring Example**

Connect the Robo Claw as shown below using two potentiometers. Short JP3 (BEC ON) and set switch SW4 to ON (Mixing Mode). You can also use the below wire example with SW4 OFF. Center the potentiometers before applying power or the attached motors will start moving. S1 potentiometer in mix mode (SW4) will control forward and reverse. S2 potentiometer in mix mode (SW4) will control turning (LEFT / RIGHT).

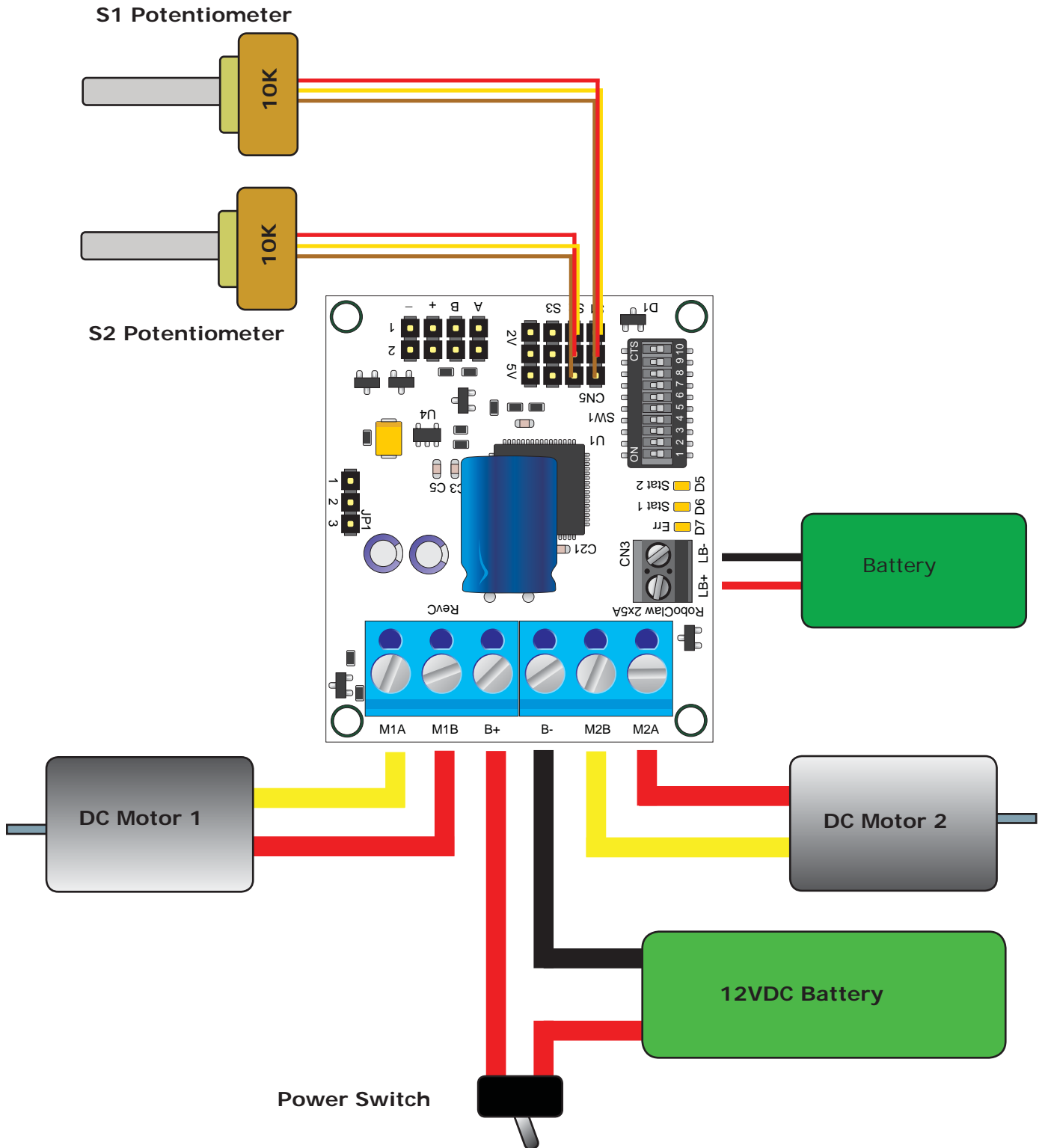

# Simple Serial

**Mode 3 - Simple Serial**

Simple Serial mode set SW1 = OFF, SW2 = ON and SW3 = OFF. In this mode S1 accepts TTL level byte commands. Robo Claw is receive only and uses 8N1 format which is 8 bits, no parity bits and 1 stop bit. If your using a microcontroller you can interface directly to Robo Claw. If your using a PC a level shifting circuit is required (MAX232). The baud rate is set by the dip switches.

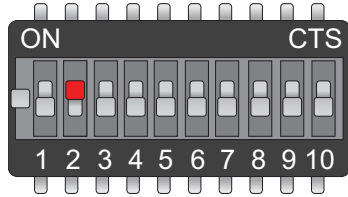

**Switch 1 - Slave Select**

SW1 = ON: Turns slave select ON. Slave select is used when more than one Robo Claw is on the same serial buss. When slave select is set to ON the S2 pin becomes the select pin. Set S2 high (5V) and Robo Claw will execute the next commands. Set S2 low (0V) and Robo Claws will ignore all sent commands.

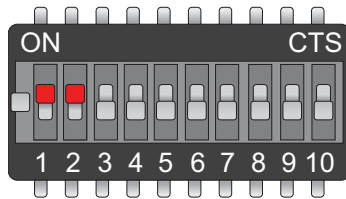

**Simple Serial Slave**

Setting up the Robo Claw for serial slave is straight forward. Make sure all Robo Claws share a common signal ground (GND) shown by the black wire. P0 (Brown line) is connected to S1 of all 3 Robo Claws which is the serial in of the Robo Claw. P1, P2 and P3 are connected to S2. Only one MCU pin is connected to each Robo Claws S2 pin. To enable Robo Claw hold S2 high otherwise any commands sent is ignored.

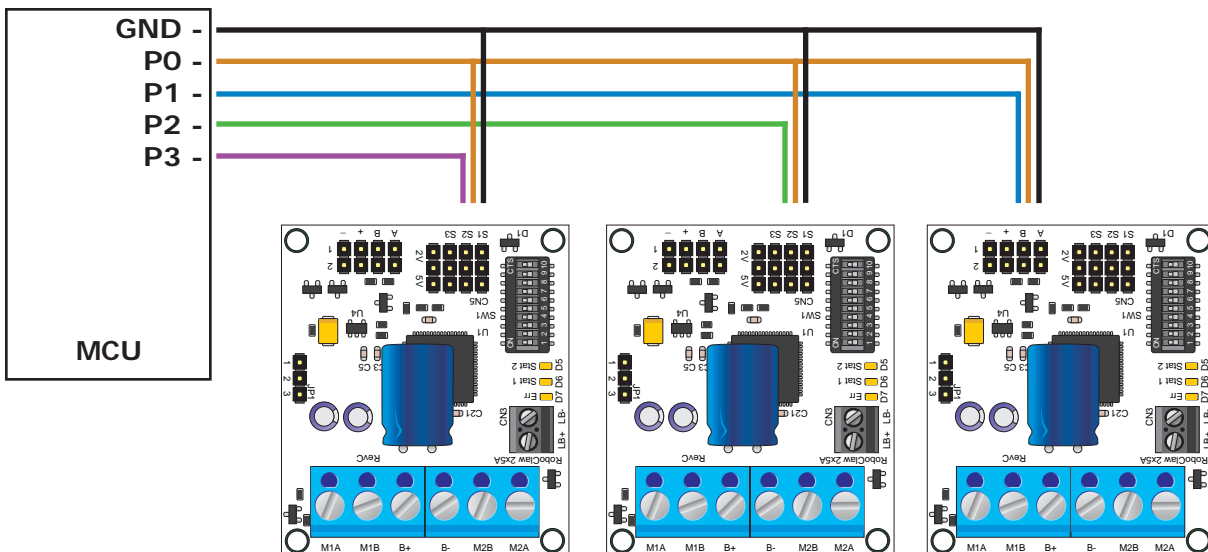



**Baud Rate**

Robo Claw supports 4 baud rates in serial mode. The baud rate is selected by setting switch 4 and 5.

Baud Rate	SW4	SW5
2400	OFF	OFF
9600	ON	OFF
19200	OFF	ON
38400	ON	ON

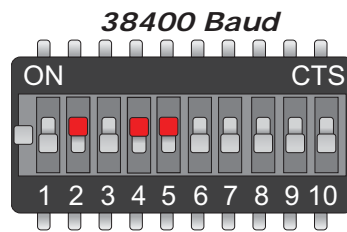
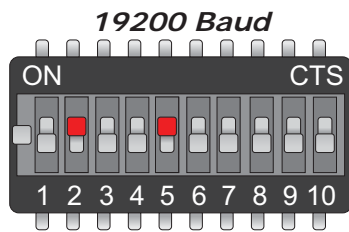
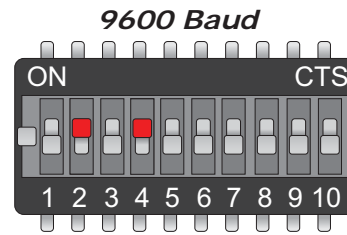
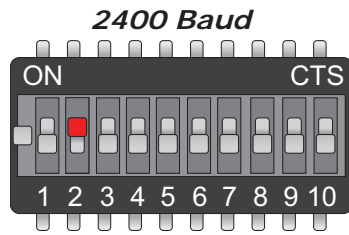
**Simple Serial Command Syntax**

The Robo Claw simple serial is setup to control both motors with one byte sized command character. Since a byte can be anything from 0 to 255 the control of each motor is split. 1 to 127 controls channel 1 and 128 to 255 controls channel 2. Command character 0 will shut down both channels. Any characters in between will control speed, direction of each channel.

Character	Function
0	Shuts Down Channel 1 and 2
1	Channel 1 - Full Reverse
64	Channel 1 - Stop
127	Channel 1 - Full Forward
128	Channel 2 - Full Reverse
192	Channel 2 - Stop
255	Channel 2 - Full Forward

**Simple Serial Wiring Example**

In simple serial mode the Robo Claw can only receive serial data.

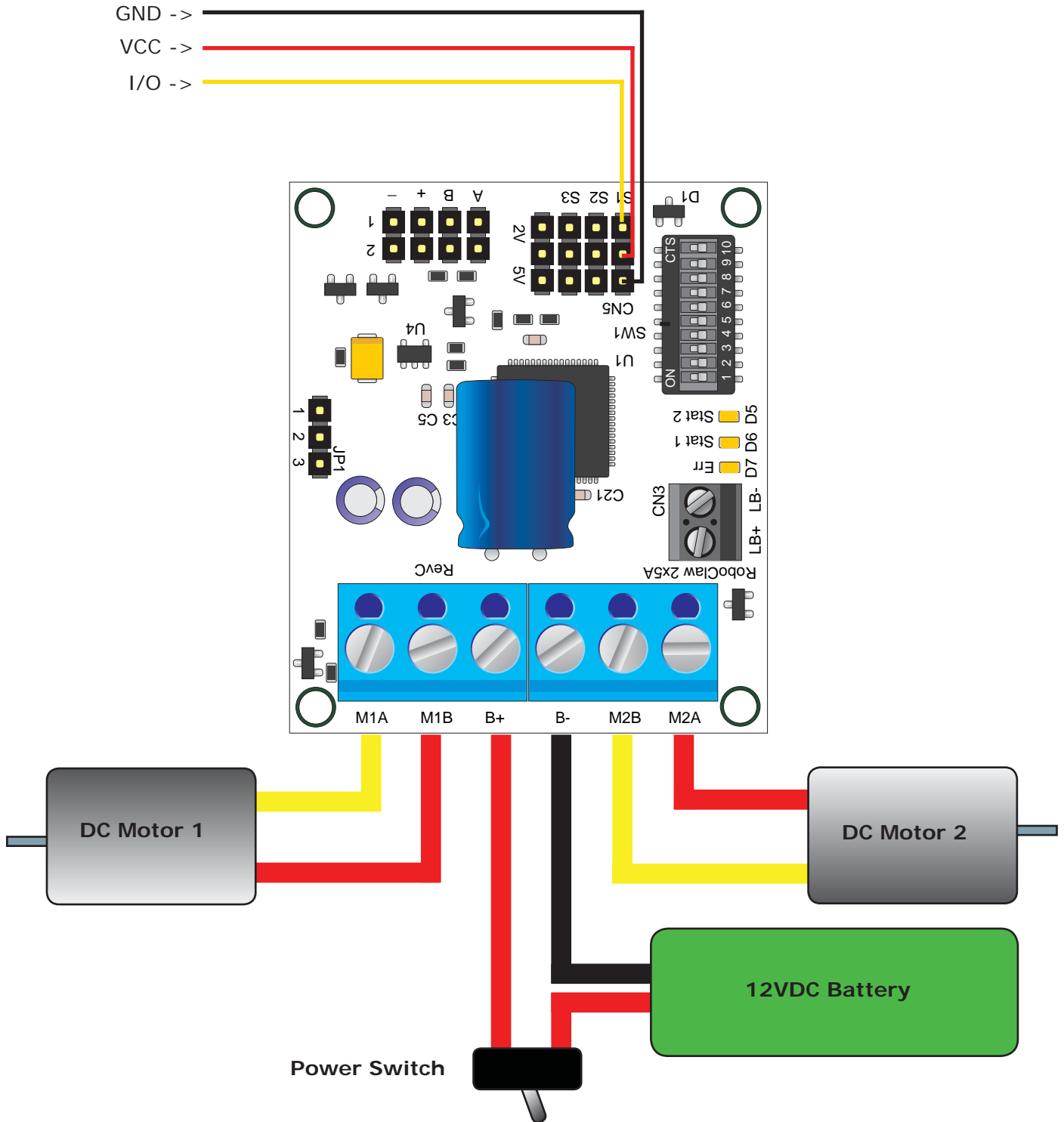

### Simple Serial Example

The following example will start both channels in reverse, stop, then full speed forward. The program was written and tested with a BasicATOM Pro and P0 connected to S1. Set switch SW2 and SW5 to ON.

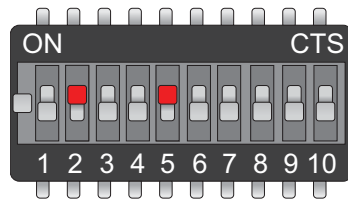

```

;Basic Micro Robo Claw Simple Serial Test
;Switch settings: SW2=ON and SW5=ON
;Make sure BAP and Robo Claw share common GND!

Main
  Serout P15, i19200, [0] ;Full stop both channels
  Pause 500
  Serout P15, i19200, [96,224] ;Foward slowly
  Pause 3000
  Serout P15, i19200, [127,255] ;Foward fast
  Pause 3000

  Serout P15, i19200, [64,192] ;Full stop both channels
  Pause 500
  Serout P15, i19200, [32,160] ;Reverse slowly
  Pause 3000
  Serout P15, i19200, [1,128] ;Reverse fast
  Pause 3000
Goto Main

```

# Packet Serial

### Mode 4 - Packet Serial

Packet serial mode set SW3 = ON and then selected address. See table below. Packet serial is used to communicate more sophisticated instructions to Robo Claw. Robo Claw can send or receive serial data in packet mode. The basic command structures consists of address byte, command byte, data bytes and a checksum. The amount of data each command will send or receive can vary. In packet mode the Robo Claw includes a scripting language to allow for more complex functions when using quadrature decoding abilities.

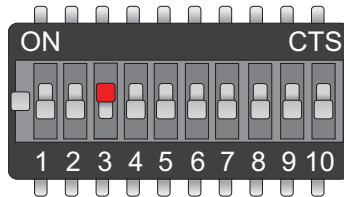

### Baud Rate

Packet serial supports the same baud rate modes as simple serial and uses the same RS232 8N1 format. The following table defines the available baud rates and their respective switch settings.

Baud Rate	SW4	SW5
2400	OFF	OFF
9600	ON	OFF
19200	OFF	ON
38400	ON	ON

### Address

When using packet serial each Robo Claw must be assigned a unique address. With up to 8 addresses available you can have up to 8 Robo Claws bussed on the same RS232 port. The following table defines the addresses and their respective switch settings.

Address	SW1	SW6	SW7
128 (0x80)	OFF	OFF	OFF
129 (0x81)	OFF	ON	OFF
130 (0x82)	OFF	OFF	ON
131 (0x83)	OFF	ON	ON
132 (0x84)	ON	OFF	OFF
133 (0x85)	ON	ON	OFF
134 (0x86)	ON	OFF	ON
135 (0x87)	ON	ON	ON

**CRC Checksum Calculation**

All packet serial commands use a 7 bit CRC checksum to prevent corrupt commands from being executed. Since the Robo Claw expects a 7bit value the 8th bit is masked. The basic CRC checksum is calculated as follows:

$$\text{Address} + \text{Command} + \text{Data} = \text{Checksum}$$

To mask the 8th bit you use can a simple math expression called AND as shown below:

```
Serout P15, i19200, [128, 0, 127, (255 & 0X7F)]
```

The hexadecimal value 0X7F is used to mask the 8th bit. You can also use a binary value of 01111111 as shown below:

```
Serout P15, i19200, [128, 0, 127, (255 & %01111111)]
```

**Commands 0 - 7 Standard Commands**

The following commands are the standard set of commands used with packet mode. The command syntax is the same for commands 0 to 7:

*Address, Command, ByteValue, CRC*

**0 - Drive Forward M1**

Drive motor 1 forward. Valid data range is 0 - 127. A value of 127 = full speed forward, 64 = about half speed forward and 0 = full stop. Example with Robo Claw address set to 128:

```
Serout P15, i19200, [128, 0, 127, (255 & 0X7F)] ;M1 full speed forward
```

**1 - Drive Backwards M1**

Drive motor 1 backwards. Valid data range is 0 - 127. A value of 127 full speed backwards, 64 = about half speed backward and 0 = full stop. Example with Robo Claw address set to 128:

```
Serout P15, i19200, [128, 1, 127, (256 & 0X7F)] ;M1 full speed forward
```

**2 - Set Minimum Main Voltage**

Sets main battery (B- / B+) minimum voltage level. If the battery voltages drops below the set voltage level Robo Claw will shut down. The value is cleared at start up and must set after each power up. The voltage is set in .2 volt increments. A value of 0 sets the minimum value allowed which is 6V. The valid data range is 0 - 120 (6V - 30V). The formula for calculating the voltage is: (Desired Volts - 6) x 5 = Value. Examples of valid values are 6V = 0, 8V = 10 and 11V = 25. Example with Robo Claw address set to 128:

```
Serout P15, i19200, [128, 2, 25, (165 & 0X7F)]
```

**3 - Set Maximum Main Voltage**

Sets main battery (B- / B+) maximum voltage level. The valid data range is 0 - 154 (0V - 30V). If you are using a battery of any type you can ignore this setting. During regenerative braking a back voltage is applied to charge the battery. When using an ATX type power supply if it senses anything over 16V it will shut down. By setting the maximum voltage level, Robo Claw before exceeding it will go into hard breaking mode until the voltage drops below the maximum value set. The formula for calculating the voltage is: Desired Volts x 5.12 = Value. Examples of valid values are 12V = 62, 16V = 82 and 24V = 123. Example with Robo Claw address set to 128:

```
Serout P15, i19200, [128, 3, 82, (213 & 0X7F)]
```

**4 - Drive Forward M2**

Drive motor 2 forward. Valid data range is 0 - 127. A value of 127 full speed forward, 64 = about half speed forward and 0 = full stop. Example with Robo Claw address set to 128:

```
Serout P15, i19200, [128, 4, 127, (259 & 0X7F)] ;M2 full speed forward
```

**5 - Drive Backwards M2**

Drive motor 2 backwards. Valid data range is 0 - 127. A value of 127 full speed backwards, 64 = about half speed backward and 0 = full stop. Example with Robo Claw address set to 128:

```
Serout P15, i19200, [128, 5, 127, (260 & 0X7F)] ;M2 full speed forward
```

**6 - Drive M1 (7 Bit)**

Drive motor 1 forward and reverse. Valid data range is 0 - 127. A value of 0 = full speed reverse, 64 = stop and 127 = full speed forward. Example with Robo Claw address set to 128:

```
Serout P15, i19200, [128, 6, 96, (230 & 0X7F)] ;M1 half speed forward
```

**7 - Drive M2 (7 Bit)**

Drive motor 2 forward and reverse. Valid data range is 0 - 127. A value of 0 = full speed reverse, 64 = stop and 127 = full speed forward. Example with Robo Claw address set to 128:

```
Serout P15, i19200, [128, 7, 32, (167 & 0X7F)] ;M2 half speed reverse
```



**Commands 8 - 13 Mix Mode Commands**

The following commands are mix mode commands and used to control speed and turn. Before a command is executed valid drive and turn data is required. You only need to send both data packets once. After receiving both valid drive and turn data Robo Claw will begin to operate. At this point you only need to update turn or drive data.

**8 - Drive Forward**

Drive forward in mix mode. Valid data range is 0 - 127. A value of 0 = full stop and 127 = full forward. Example with Robo Claw address set to 128:

```
Serout P15, i19200, [128, 8, 127, (263 & 0x7F)] ;full speed forward
```

**9 - Drive Backwards**

Drive backwards in mix mode. Valid data range is 0 - 127. A value of 0 = full stop and 127 = full reverse. Example with Robo Claw address set to 128:

```
Serout P15, i19200, [128, 9, 127, (264 & 0x7F)] ;full speed reverse
```

**10 - Turn right**

Turn right in mix mode. Valid data range is 0 - 127. A value of 0 = stop turn and 127 = full speed turn. Example with Robo Claw address set to 128:

```
Serout P15, i19200, [128, 10, 127, (265 & 0x7F1)] ;full speed right turn
```

**11 - Turn left**

Turn left in mix mode. Valid data range is 0 - 127. A value of 0 = stop turn and 127 = full speed turn. Example with Robo Claw address set to 128:

```
Serout P15, i19200, [128, 11, 127, (266 & 0x7F)] ;full speed left turn
```

**12 - Drive Forward or Backward (7 Bit)**

Drive forward or backwards. Valid data range is 0 - 127. A value of 0 = full backward, 64 = stop and 127 = full forward. Example with Robo Claw address set to 128:

```
Serout P15, i19200, [128, 12, 96, (236 & 0x7F)] ;medium speed forward
```

**13 - Turn Left or Right (7 Bit)**

Turn left or right. Valid data range is 0 - 127. A value of 0 = full left, 0 = stop turn and 127 = full right. Example with Robo Claw address set to 128:

```
Serout P15, i19200, [128, 13, 0, (141 & 0x7F)] ;full speed turn left
```

**Packet Serial Wiring**

In packet mode the Robo Claw can transmit and receive serial data. Since Robo Claw is transmitting data it is a good idea to use a processor with a hardware serial port like the BasicATOM Pro.

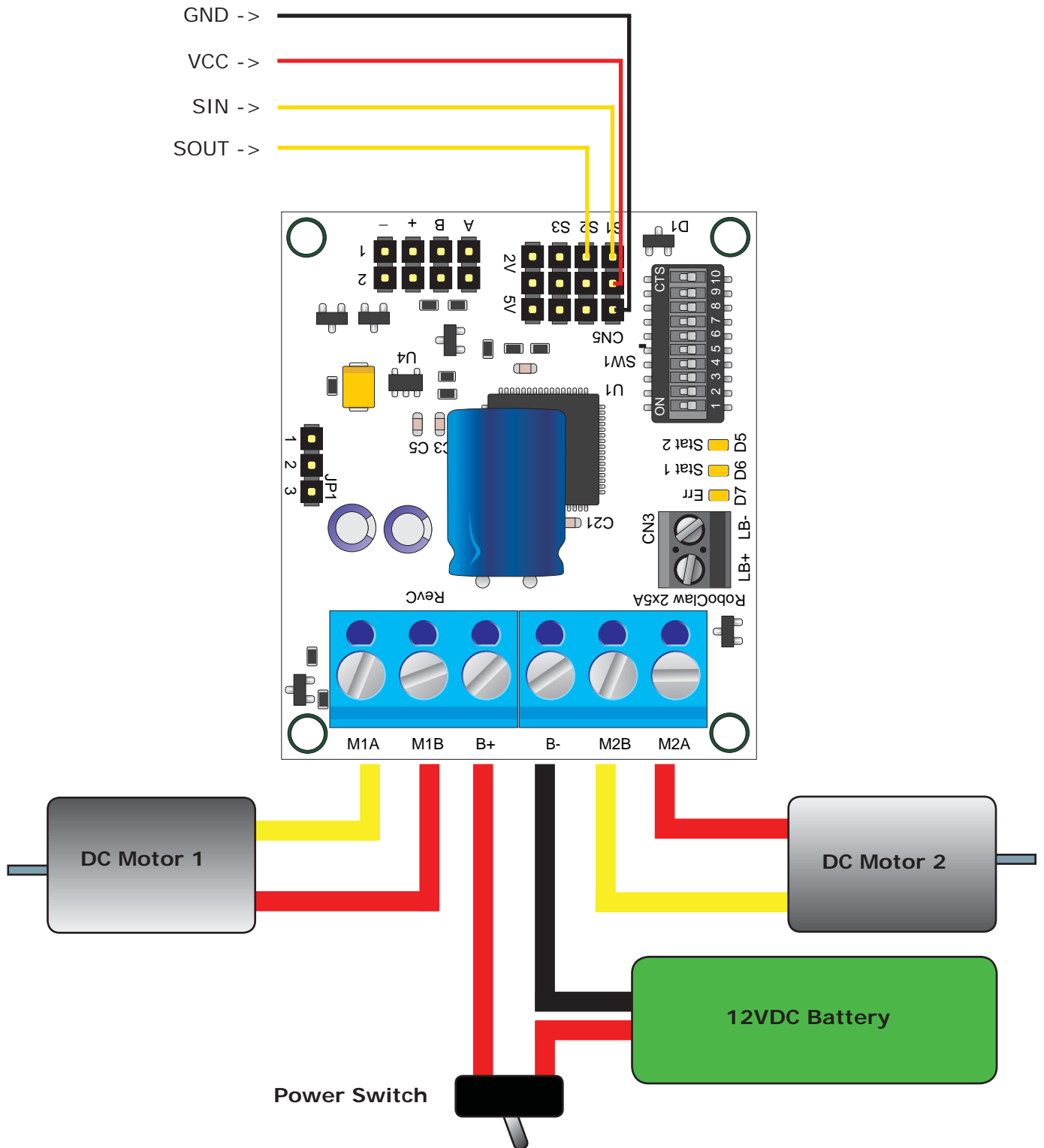

### Packet Serial Example

The following example will start both channels independently. Then start turns using mix mode command that handles both channels from one command. The program was written and tested with a BasicATOM Pro and P15 connected to S1. Set switch SW3 and SW5 to ON.

```
;Basic Micro Robo Claw Packet Serial Test Commands 0 to 13.
;Switch settings: SW3=ON and SW5=ON.

Main
  Pause 2000
  Serout P15, i19200, [128, 0, 127, (255 & 0x7F)];M1 full speed forward
  Serout P15, i19200, [128, 4, 127, (259 & 0x7F)];M2 full speed forward

  Pause 1000
  Serout P15, i19200, [128, 0, 0, (128 & 0x7F)];M1 stop
  Serout P15, i19200, [128, 4, 0, (132 & 0x7F)];M2 stop

  Pause 1000
  Serout P15, i19200, [128, 1, 127, (256 & 0x7F)];M1 full speed backwards
  Serout P15, i19200, [128, 5, 127, (260 & 0x7F)];M1 full speed backwards

  Pause 1000
  Serout P15, i19200, [128, 0, 0, (128 & 0x7F)];M1 stop
  Serout P15, i19200, [128, 4, 0, (132 & 0x7F)];M2 stop

  Pause 1000
  Serout P15, i19200, [128, 10, 127, (265 & 0x7F)];Mix mode right full speed

  Pause 1000
  Serout P15, i19200, [128, 10, 0, (138 & 0x7F)];Mix mode stop

  Pause 1000
  Serout P15, i19200, [128, 11, 127, (266 & 0x7F)];Mix mode left full speed

  Pause 1000
  Serout P15, i19200, [128, 11, 0, (139 & 0x7F)];Mix mode stop
Goto Main
```

# Battery and Version Information

## 21 - Read Firmware Version

Read Robo Claw firmware version. Returns up to 32 bytes and is terminated by a null character. Command syntax:

```
Sent: [Address, CMD]
Received: ["RoboClaw 10.2A v1.3.9, CRC]
```

The command will return up to 32 bytes. The return string includes the product name and firmware version. The return string is terminated with a null (0) character. This is done so the version information can be read from a standard PC terminal window.

```
hserout [128, 21] ;read firmware version
hserin [Str VersionByte\32\0, CRC]
```

## 24 - Read Main Battery Voltage Level

Read the main battery voltage level connected to B+ and B- terminals. The voltage is returned in 10ths of a volt. Command syntax:

```
Sent: [Address, CMD]
Received: [Value.Byte1, Value.Byte0, CRC]
```

The command will return 3 bytes. Byte 1 and 2 make up a word variable which is received MSB first and is 10th of a volt. A returned value of 300 would equal 30V. Byte 3 is the CRC. It is calculated the same way as sending a command and can be used to validate the data. The following example will read the main battery voltage with Robo Claw address set to 128.

```
hserout [128, 24] ;read main battery voltage
hserin [Value.Byte1, Value.Byte0, CRC]
```

## 25 - Read Logic Battery Voltage Level

Read a logic battery voltage level connected to LB+ and LB- terminals. The voltage is returned in 10ths of a volt. Command syntax:

```
Sent: [Address, CMD]
Received: [Value.Byte1, Value.Byte0, CRC]
```

The command will return 3 bytes. Byte 1 and 2 make up a word variable which is received MSB first and is 10th of a volt. A returned value of 50 would equal 5V. Byte 3 is the CRC. It is calculated the same way as sending a command and can be used to validate the data. The following example will read the main battery voltage with Robo Claw address set to 128.

```
hserout [128, 25] ;read logic battery voltage
hserin [Value.Byte1, Value.Byte0, CRC]
```

**26 - Set Minimum Logic Voltage Level**

Sets logic input (LB- / LB+) minimum voltage level. If the battery voltages drops below the set voltage level Robo Claw will shut down. The value is cleared at start up and must set after each power up. The voltage is set in .2 volt increments. A value of 0 sets the minimum value allowed which is 3V. The valid data range is 0 - 120 (6V - 28V). The formula for calculating the voltage is:  $(\text{Desired Volts} - 6) \times 5 = \text{Value}$ . Examples of valid values are 3V = 0, 8V = 10 and 11V = 25. Robo Claw example with address set to 128:

```
hserout [128, 26, 0, (154 & 0X7F)]
```

**27 - Set Maximum Logic Voltage Level**

Sets logic input (LB- / LB+) maximum voltage level. The valid data range is 0 - 144 (0V - 28V). By setting the maximum voltage level Robo Claw will go into shut down and requires a hard reset to recovers. The formula for calculating the voltage is:  $\text{Desired Volts} \times 5.12 = \text{Value}$ . Examples of valid values are 12V = 62, 16V = 82 and 24V = 123. Robo Claw example with address set to 128:

```
hserout [128, 27, 82, (213 & 0X7F)]
```

**Main Battery Voltage Levels**

The main battery levels are set in a similar way as the logic battery. See command 2 and 3 for details.

# Quadrature Decoding

### Quadrature Decoding

Handling the quadrature encoders is done using packet serial. All the switch settings still apply in to enabling packet serial and setting the desired baud rates. See Mode - Packet Serial. The following commands deal specifically with the dual quadrature decoders built into Robo Claw.

### CRC Checksum Calculation

All packet serial commands use a 7 bit CRC checksum to prevent corrupt commands from being executed. Since the Robo Claw expects a 7bit value the 8th bit is masked. The basic CRC checksum is calculated as follows:

$$\text{Address} + \text{Command} + \text{Data} = \text{Checksum}$$

To mask the 8th bit you use can a simple math expression called AND as shown below:

```
Serout P15, i19200, [128, 0, 127, (255 & 0X7F)]
```

The hexadecimal value 0X7F is used to mask the 8th bit. You can also use a binary value of 01111111 as shown below:

```
Serout P15, i19200, [128, 0, 127, (255 & %01111111)]
```



**Quadrature Encoder Wiring**

Robo Claw can read two quadrature encoders. The encoders are connected to Robo Claw using CN4. Both GND and 5 volts are present on the header to power the encoders.

In a two motor robot configuration one motor will spin clock wise (CW) while the other motor will spin counter clock wise (CCW). The A and B inputs for one of the two encoders must be reversed as shown. If either encoder is connected wrong one will count up and the other down this will cause commands like mix drive forward to not work properly.

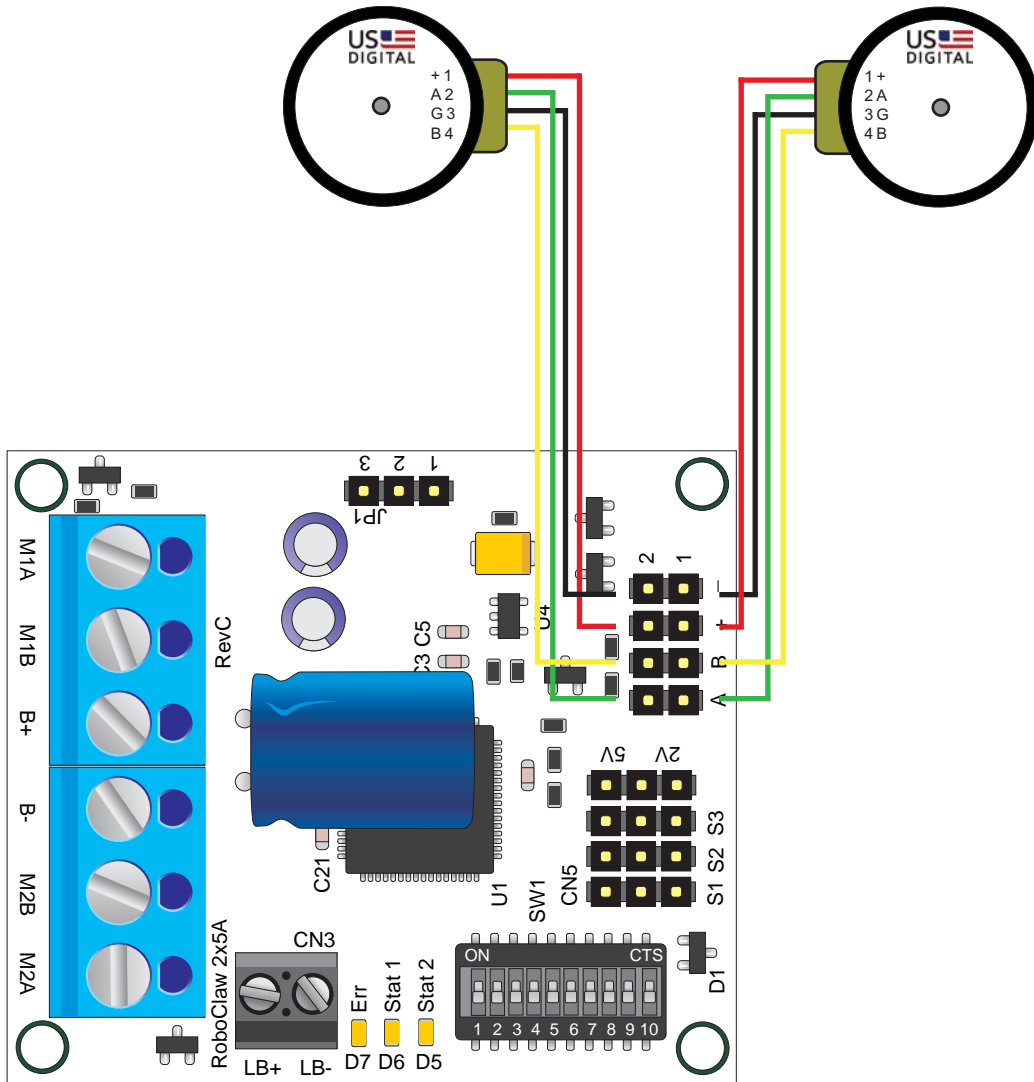

### Commands 16 - 20 Reading Quadrature Encoders

The following commands are used in dealing with the quadrature decoding counter registers. The quadrature decoder is a simple counter that counts the incoming pulses, tracks the direction and speed of each pulse. There are two registers one each for M1 and M2. (Note: A microcontroller with a hardware UART is recommended for use with packet serial modes).

Command	Description
16	Read Quadrature Encoder Register for M1.
17	Read Quadrature Encoder Register for M2.
18	Read M1 Speed in Pulses Per Second.
19	Read M2 Speed in Pulses Per Second.
20	Resets Quadrature Encoder Registers for M1 and M2.

#### 16 - Read Quadrature Encoder Register M1

Read decoder M1 counter. Since CMD 16 is a read command it does not require a CRC. However a CRC value will be returned from Robo Claw and can be used to validate the data. Command syntax:

```
Sent: [Address, CMD]
Received: [Value1.Byte3, Value1.Byte2, Value1.Byte1, Value1.Byte0, Value2, CRC]
```

The command will return 6 bytes. Byte 1,2,3 and 4 make up a long variable which is received MSB first and represents the current count which can be any value from 0 - 4,294,967,295. Each pulse from the quadrature encoder will increment or decrement the counter depending on the direction of rotation.

Byte 5 is the status byte for M1 decoder. It tracks counter underflow, direction, overflow and if the encoder is operational. The byte value represents:

```
Bit0 - Counter Underflow    (1= Underflow Occurred, Clear After Reading)
Bit1 - Direction            (0 = Forward, 1 = Backwards)
Bit2 - Counter Overflow     (1= Underflow Occurred, Clear After Reading)
Bit3 - Reserved
Bit4 - Reserved
Bit5 - Reserved
Bit6 - Reserved
Bit7 - Encoder OK          (1 = OK, 0 = FAIL)
```

Byte 6 is the CRC checksum. It is calculated the same way as sending a command. It can be used to validate the resulting data. The following example will read M1 counter register, status byte and CRC value with Robo Claw address set to 128.

```
hserout [128, 16] ;read command for M1 encoder
hserin [Value1.Byte3, Value1.Byte2, Value1.Byte1, Value1.Byte0, Value2, CRC]
```

**17 - Read Quadrature Encoder Register M2**

Read decoder M2 counter. Since CMD 16 is a read command it does not require a CRC. However a CRC value will be returned from Robo Claw and can be used to validate the data. Command syntax:

```
Sent: [Address, CMD]
Received: [Value1.Byte3, Value1.Byte2, Value1.Byte1, Value1.Byte0, Value2, CRC]
```

The command will return 6 bytes. Byte 1,2,3 and 4 make up a long variable which is received MSB first and represents the current count which can be any value from 0 - 4,294,967,295. Each pulse from the quadrature encoder will increment or decrement the counter depending on the direction of rotation.

Byte 5 is the status byte for M1 decoder. It tracks counter underflow, direction, overflow and if the encoder is operational. The byte value represents:

- Bit0 - Counter Underflow (1= Underflow Occurred, Clear After Reading)
- Bit1 - Direction (0 = Forward, 1 = Backwards)
- Bit2 - Counter Overflow (1= Underflow Occurred, Clear After Reading)
- Bit3 - Reserved
- Bit4 - Reserved
- Bit5 - Reserved
- Bit6 - Reserved
- Bit7 - Encoder OK (1 = OK, 0 = FAIL)

Byte 6 is the CRC checksum. It is calculated the same way as sending a command. It can be used to validate the resulting data. The following example will read M1 counter register, status byte and CRC value with Robo Claw address set to 128.

```
hserout [128, 17] ;read command for M2 encoder
hserin [Value1.Byte3, Value1.Byte2, Value1.Byte1, Value1.Byte0, Value2, CRC]
```

**18 - Read Speed M1**

Read M1 counter speed. Returned value is in pulses per second. Robo Claw keeps track of how many pulses received per second for both decoder channels. Since CMD 18 is a read command it does not require a CRC to be sent. However a CRC value will be returned from Robo Claw and can be used to validate the data. Command syntax:

```
Sent: [Address, CMD]
Received: [Value1.Byte3, Value1.Byte2, Value1.Byte1, Value1.Byte0, Value2, CRC]
```

The command will return 6 bytes. Byte 1,2,3 and 4 make up a long variable which is received MSB first and is the current ticks per second which can be any value from 0 - 4,294,967,295. Byte 5 is the direction (0 – forward, 1 - backward). Byte 6 is the CRC. It is calculated the same way as sending a command and can be used to validate the data. The following example will read M1 pulse per second and direction with Robo Claw address set to 128.

```
hserout [128, 18] ;read command for M1 encoder
hserin [Value1.Byte3, Value1.Byte2, Value1.Byte1, Value1.Byte0, Value2, CRC]
```

## 19 - Read Speed M2

Read M2 counter speed. Returned value is in pulses per second. Robo Claw keeps track of how many pulses received per second for both decoder channels. Since CMD 19 is a read command it does not require a CRC to be sent. However a CRC value will be returned from Robo Claw and can be used to validate the data. Command syntax:

```
Sent: [Address, CMD]
Received: [Value1.Byte3, Value1.Byte2, Value1.Byte1, Value1.Byte0, Value2, CRC]
```

The command will return 6 bytes. Byte 1,2,3 and 4 make up a long variable which is received MSB first and is the current ticks per second which can be any value from 0 - 4,294,967,295. Byte 5 is the direction (0 – forward, 1 - backward). Byte 6 is the CRC. It is calculated the same way as sending a command and can be used to validate the data. The following example will read M2 pulse per second and direction with Robo Claw address set to 128.

```
hserout [128, 19] ;read command for M2 encoder
hserin [Value1.Byte3, Value1.Byte2, Value1.Byte1, Value1.Byte0, Value2, CRC]
```

## 20 - Reset Quadrature Encoder Counters

Will reset both quadrature decoder counters to zero. Since CMD 20 is a write command a CRC value is required. Command syntax and example:

```
hserout [128, 20, (148 & %01111111)]; resets encoder registers
```

**Commands 28 - 48 Motor Control by Quadrature Encoders**

The following commands are used to control motor speeds, acceleration and distance using the quadrature encoders. All speeds are given in quad pulses per second (QPPS) unless otherwise stated. Quadrature encoders of different types and manufactures can be used. However many have different resolutions and maximum speeds at which they operate. So each quadrature encoder will produce a different range of pulses per second.

Command	Description
28	Set PID Constants for M1.
29	Set PID Constants for M2.
30	Read Current M1 Speed Resolution 125th of a Second.
31	Read Current M2 Speed Resolution 125th of a Second.
32	Drive M1 With Signed Duty Cycle.
33	Drive M2 With Signed Duty Cycle.
34	Mix Mode Drive M1 / M2 With Signed Duty Cycle.
35	Drive M1 With Signed Speed.
36	Drive M2 With Signed Speed.
37	Mix Mode Drive M1 / M2 With Signed Speed.
38	Drive M1 With Signed Speed And Acceleration.
39	Drive M2 With Signed Speed And Acceleration.
40	Mix Mode Drive M1 / M2 With Speed And Acceleration.
41	Drive M1 With Signed Speed And Distance. Buffered.
42	Drive M2 With Signed Speed And Distance. Buffered.
43	Mix Mode Drive M1 / M2 With Speed And Distance. Buffered.
44	Drive M1 With Signed Speed, Acceleration and Distance. Buffered.
45	Drive M2 With Signed Speed, Acceleration and Distance. Buffered.
46	Mix Mode Drive M1 / M2 With Speed, Acceleration And Distance. Buffered.
47	Read Buffer Length.
48	Set PWM Resolution.

## 28 - Set PID Constants M1

Several motor and quadrature combinations can be used with Robo Claw. In some cases the default PID values will need to be tuned for the systems being driven. This gives greater flexibility in what motor and encoder combinations can be used. The Robo Claw PID system consist of four constants starting with QPPS, P = Proportional, I= Integral and D= Derivative. The defaults values are:

```
QPPS = 44000
P = 0x00000200
I = 0x00000100
D = 0x00000080
```

QPPS is the speed of the encoder when the motor is at 100% power. P, I, D are the default values used after a reset. Command syntax:

```
Sent: [Address, CMD, D(4 bytes), P(4 bytes), I(4 bytes), QPPS(4 byte), CRC]
```

Each value is made up of 4 bytes for a long. To write the registers a CRC value is used. This prevents an accidental write.

## 29 - Set PID Constants M2

Several motor and quadrature combinations can be used with Robo Claw. In some cases the default PID values will need to be tuned for the systems being driven. This gives greater flexibility in what motor and encoder combinations can be used. The Robo Claw PID system consist of four constants starting with QPPS, P = Proportional, I= Integral and D= Derivative. The defaults values are:

```
QPPS = 44000
P = 0x00000200
I = 0x00000100
D = 0x00000080
```

QPPS is the speed of the encoder when the motor is at 100% power. P, I, D are the default values used after a reset. Command syntax:

```
Sent: [Address, CMD, D(4 bytes), P(4 bytes), I(4 bytes), QPPS(4 byte), CRC]
```

Each value is made up of 4 bytes for a long. To write the registers a CRC value is used. This prevents an accidental write.

### 30 - Read Current Speed M1

Read the current pulse per 125th of a second. This is a high resolution version of command 18 and 19. Command 30 can be used to make a independent PID routine. The resolution of the command is required to create a PID routine using any microcontroller or PC used to drive Robo Claw. The command syntax:

```
Sent: [Address, CMD]
Received: [Speed(4 bytes), CRC]
```

The command will return 4 bytes, MSB sent first for a long. A CRC is returned in order to validate the data returned.

### 31 - Read Current Speed M2

Read the current pulse per 125th of a second. This is a high resolution version of command 18 and 19. Command 31 can be used to make a independent PID routine. The resolution of the command is required to create a PID routine using any microcontroller or PC used to drive Robo Claw. The command syntax:

```
Sent: [Address, CMD]
Received: [Speed(4 bytes), CRC]
```

The command will return 4 bytes, MSB sent first for a long. A CRC is returned in order to validate the data returned.

### 32 - Drive M1 With Signed Duty Cycle

Drive M1 using a duty cycle value. The default PWM is 8bit resolution. The default value can be changed see CMD 48. The duty cycle is used to control the speed of the motor without a quadrature encoder. A value used to drive one motor at 50% will be differ from one motor to the next. The command syntax:

```
Sent: [Address, CMD, Duty(2 Bytes), CRC]
```

The duty value is signed and the default range is 8bits. The default PWM resolution can be changed for more range. To change the resolution see command 48.

### 33 - Drive M2 With Signed Duty Cycle

Drive M2 using a duty cycle value. The default PWM is 8bit resolution. The default value can be changed see CMD 48. The duty cycle is used to control the speed of the motor without a quadrature encoder. A value used to drive one motor at 50% will be differ from one motor to the next. The command syntax:

```
Sent: [Address, CMD, Duty(2 Bytes), CRC]
```

The duty value is signed and the default range is 8bits. The default PWM resolution can be changed for more range. To change the resolution see command 48.

### 34 - Mix Mode Drive M1 / M2 With Signed Duty Cycle

Drive both M1 and M2 using a duty cycle value. The default PWM is 8bit resolution. The default value can be changed see CMD 48. The duty cycle is used to control the speed of the motor without a quadrature encoder. A value used to drive one motor at 50% will be differ from one motor to the next. The command syntax:

```
Sent: [Address, CMD, DutyM1(2 Bytes), DutyM2(2 Bytes), CRC]
```

The duty value is signed and the default range is 8bits. The default PWM resolution can be changed for more range. To change the resolution see command 48.

### 35 - Drive M1 With Signed Speed

Drive M1 using a speed value. The sign indicates which direction the motor will turn. This command is used to drive the motor by quad pulses per second. Different quadrature encoders will have different rates at which they generate the incoming pulses. The values used will differ from one encoder to another. Once a value is sent the motor will begin to accelerate as fast as possible until the defined rate is reached. The command syntax:

```
Sent: [Address, CMD, Qspeed(4 Bytes), CRC]
```

4 Bytes (long) are used to express the pulses per second. Quadrature encoders send 4 pulses per tick. So 1000 ticks would be counted as 4000 pulses.

### 36 - Drive M2 With Signed Speed

Drive M2 with a speed value. The sign indicates which direction the motor will turn. This command is used to drive the motor by quad pulses per second. Different quadrature encoders will have different rates at which they generate the incoming pulses. The values used will differ from one encoder to another. Once a value is sent, the motor will begin to accelerate as fast as possible until the rate defined is reached. The command syntax:

```
Sent: [Address, CMD, Qspeed(4 Bytes), CRC]
```

4 Bytes (long) are used to expressed the pulses per second. Quadrature encoders send 4 pulses per tick. So 1000 ticks would be counted as 4000 pulses.



### 37 - Mix Mode Drive M1 / M2 With Signed Speed

Drive M1 and M2 in the same command using a signed speed value. The sign indicates which direction the motor will turn. This command is used to drive both motors by quad pulses per second. Different quadrature encoders will have different rates at which they generate the incoming pulses. The values used will differ from one encoder to another. Once a value is sent the motor will begin to accelerate as fast as possible until the rate defined is reached. The command syntax:

```
Sent: [Address, CMD, QspeedM1(4 Bytes), QspeedM2(4 Bytes), CRC]
```

4 Bytes (long) are used to express the pulses per second. Quadrature encoders send 4 pulses per tick. So 1000 ticks would be counted as 4000 pulses.

### 38 - Drive M1 With Signed Speed And Acceleration

Drive M1 with a signed speed and acceleration value. The sign indicates which direction the motor will run. The acceleration values are not signed. This command is used to drive the motor by quad pulses per second and using an acceleration value for ramping. Different quadrature encoders will have different rates at which they generate the incoming pulses. The values used will differ from one encoder to another. Once a value is sent the motor will begin to accelerate incrementally until the rate defined is reached. The command syntax:

```
Sent: [Address, CMD, Accel(4 Bytes), Qspeed(4 Bytes), CRC]
```

4 Bytes (long) are used to express the pulses per second. Quadrature encoders send 4 pulses per tick. So 1000 ticks would be counted as 4000 pulses. The acceleration is measured in speed per second. An acceleration value of 12,000 QPPS with a speed of 12,000 QPPS would accelerate a motor from 0 to 12,000 QPPS in 1 second. Another example would be an acceleration value of 24,000 QPPS and a speed value of 12,000 QPPS would accelerate the motor to 12,000 QPPS in 0.5 seconds.

### 39 - Drive M2 With Signed Speed And Acceleration

Drive M2 with a signed speed and acceleration value. The sign indicates which direction the motor will run. The acceleration value is not signed. This command is used to drive the motor by quad pulses per second and using an acceleration value for ramping. Different quadrature encoders will have different rates at which they generate the incoming pulses. The values used will differ from one encoder to another. Once a value is sent the motor will begin to accelerate incrementally until the rate defined is reached. The command syntax:

```
Sent: [Address, CMD, Accel(4 Bytes), Qspeed(4 Bytes), CRC]
```

4 Bytes (long) are used to express the pulses per second. Quadrature encoders send 4 pulses per tick. So 1000 ticks would be counted as 4000 pulses. The acceleration is measured in speed per second. An acceleration value of 12,000 QPPS with a speed of 12,000 QPPS would accelerate a motor from 0 to 12,000 QPPS in 1 second. Another example would be an acceleration value of 24,000 QPPS and a speed value of 12,000 QPPS would accelerate the motor to 12,000 QPPS in 0.5 seconds.

#### 40 - Mix Mode Drive M1 / M2 With Speed And Acceleration

Drive M1 and M2 in the same command using one value for acceleration and two signed speed values for each motor. The sign indicates which direction the motor will run. The acceleration value is not signed. The motors are sync during acceleration. This command is used to drive the motor by quad pulses per second and using an acceleration value for ramping. Different quadrature encoders will have different rates at which they generate the incoming pulses. The values used will differ from one encoder to another. Once a value is sent the motor will begin to accelerate incrementally until the rate defined is reached. The command syntax:

```
Sent: [Address, CMD, Accel(4 Bytes), QspeedM1(4 Bytes), QspeedM2(4 Bytes), CRC]
```

4 Bytes (long) are used to express the pulses per second. Quadrature encoders send 4 pulses per tick. So 1000 ticks would be counted as 4000 pulses. The acceleration is measured in speed per second. An acceleration value of 12,000 QPPS with a speed of 12,000 QPPS would accelerate a motor from 0 to 12,000 QPPS in 1 second. Another example would be an acceleration value of 24,000 QPPS and a speed value of 12,000 QPPS would accelerate the motor to 12,000 QPPS in 0.5 seconds.

#### 41 - Buffered M1 Drive With Signed Speed And Distance

Drive M1 with a signed speed and distance value. The sign indicates which direction the motor will run. The distance value is not signed. This command is buffered. This command is used to control the top speed and total distance traveled by the motor. Each motor channel M1 and M2 have separate buffers. This command will execute immediately if no other command for that channel is executing, otherwise the command will be buffered in the order it was sent. Any buffered or executing command can be stopped when a new command is issued by setting the Buffer argument. All values used are in quad pulses per second. The command syntax:

```
Sent: [Address, CMD, QSpeed(4 Bytes), Distance(4 Bytes), Buffer(1 Byte), CRC]
```

4 Bytes(long) are used to express the pulses per second. The Buffer argument can be set to a 1 or 0. If a value of 0 is used the command will be buffered and executed in the order sent. If a value of 1 is used the current running command is stopped, any other commands in the buffer are deleted and the new command is executed.

#### 42 - Buffered M2 Drive With Signed Speed And Distance

Drive M2 with a speed and distance value. The sign indicates which direction the motor will run. The distance value is not signed. This command is buffered. Each motor channel M1 and M2 have separate buffers. This command will execute immediately if no other command for that channel is executing, otherwise the command will be buffered in the order it was sent. Any buffered or executing command can be stopped when a new command is issued by setting the Buffer argument. All values used are in quad pulses per second. The command syntax:

```
Sent: [Address, CMD, QSpeed(4 Bytes), Distance(4 Bytes), Buffer(1 Byte), CRC]
```

4 Bytes(long) are used to express the pulses per second. The Buffer argument can be set to a 1 or 0. If a value of 0 is used the command will be buffered and executed in the order sent. If a value of 1 is used the current running command is stopped, any other commands in the buffer are deleted and the new command is executed.

**43 - Buffered Mix Mode Drive M1 / M2 With Signed Speed And Distance**

Drive M1 and M2 with a speed and distance value. The sign indicates which direction the motor will run. The distance value is not signed. This command is buffered. Each motor channel M1 and M2 have separate buffers. This command will execute immediately if no other command for that channel is executing, otherwise the command will be buffered in the order it was sent. Any buffered or executing command can be stopped when a new command is issued by setting the Buffer argument. All values used are in quad pulses per second. The command syntax:

```
Sent: [Address, CMD, QSpeedM1(4 Bytes), DistanceM1(4 Bytes),
      QSpeedM2(4 Bytes), DistanceM2(4 Bytes), Buffer(1 Byte), CRC]
```

4 Bytes(long) are used to express the pulses per second. The Buffer argument can be set to a 1 or 0. If a value of 0 is used the command will be buffered and executed in the order sent. If a value of 1 is used the current running command is stopped, any other commands in the buffer are deleted and the new command is executed.

**44 - Buffered M1 Drive With Signed Speed, Accel And Distance**

Drive M1 with a speed, acceleration and distance value. The sign indicates which direction the motor will run. The acceleration and distance values are not signed. This command is used to control the motors top speed, total distanced traveled and at what incremental acceleration value to use until the top speed is reached. Each motor channel M1 and M2 have separate buffers. This command will execute immediately if no other command for that channel is executing, otherwise the command will be buffered in the order it was sent. Any buffered or executing command can be stopped when a new command is issued by setting the Buffer argument. All values used are in quad pulses per second. The command syntax:

```
Sent: [Address, CMD, Accel(4 bytes), QSpeed(4 Bytes), Distance(4 Bytes),
      Buffer(1 Byte), CRC]
```

4 Bytes(long) are used to express the pulses per second. The Buffer argument can be set to a 1 or 0. If a value of 0 is used the command will be buffered and executed in the order sent. If a value of 1 is used the current running command is stopped, any other commands in the buffer are deleted and the new command is executed.

**45 - Buffered M2 Drive With Signed Speed, Accel And Distance**

Drive M2 with a speed, acceleration and distance value. The sign indicates which direction the motor will run. The acceleration and distance values are not signed. This command is used to control the motors top speed, total distanced traveled and at what incremental acceleration value to use until the top speed is reached. Each motor channel M1 and M2 have separate buffers. This command will execute immediately if no other command for that channel is executing, otherwise the command will be buffered in the order it was sent. Any buffered or executing command can be stopped when a new command is issued by setting the Buffer argument. All values used are in quad pulses per second. The command syntax:

```
Sent: [Address, CMD, Accel(4 bytes), QSpeed(4 Bytes), Distance(4 Bytes),
      Buffer(1 Byte), CRC]
```

4 Bytes(long) are used to express the pulses per second. The Buffer argument can be set to a 1 or 0. If a value of 0 is used the command will be buffered and executed in the order sent. If a value of 1 is used the current running command is stopped, any other commands in the buffer are deleted and the new command is executed.

**46 - Buffered Mix Mode Drive M1 / M2 With Signed Speed, Accel And Distance**

Drive M1 and M2 with a speed, acceleration and distance value. The sign indicates which direction the motor will run. The acceleration and distance values are not signed. This command is used to control both motors top speed, total distanced traveled and at what incremental acceleration value to use until the top speed is reached. Each motor channel M1 and M2 have separate buffers. This command will execute immediately if no other command for that channel is executing, otherwise the command will be buffered in the order it was sent. Any buffered or executing command can be stopped when a new command is issued by setting the Buffer argument. All values used are in quad pulses per second. The command syntax:

```
Sent: [Address, CMD, Accel(4 Bytes), QSpeedM1(4 Bytes), DistanceM1(4 Bytes),  
QSpeedM2(4 bytes), DistanceM2(4 Bytes), Buffer(1 Byte), CRC]
```

4 Bytes(long) are used to express the pulses per second. The Buffer argument can be set to a 1 or 0. If a value of 0 is used the command will be buffered and executed in the order sent. If a value of 1 is used the current running command is stopped, any other commands in the buffer are deleted and the new command is executed.

**47 - Read Buffer Length**

Read both motor M1 and M2 buffer lengths. This command can be used to determine how many commands are waiting to execute.

```
Sent: [Address, CMD]  
Received: [BufferM1(1 Bytes), BufferM2(1 Bytes), CRC]
```

The return values represent how many commands per buffer are waiting to be executed. The maximum buffer size per motor is 24 commands.

**48 - Set PWM Resolution**

This command is used to adjust the resolution of the PWM. Different motors will produce different results when used with various PWM resolutions. On occasion a motor may emit a noise, the PWM resolution can be changed to compensation for the noise. QPPS and PID constants are reset to defaults when this command is executed. In most cases correct PID constants for higher resolution PWM should be double the previous resolutions values. For example at 8 bit resolution  $P = 0x00000200$  and at 9 bit resolution  $P = 0x00000400$ .

Sent: [Address, CMD, Resolution(1 Byte), CRC]

The resolution is 1 byte wide and ranges from 0 to 6. See the table below for each resolution and its corresponding value.

Value	Resolution	Description
0	8 Bit	+ -127
1	9 Bit	+ -255
2	10 Bit	+ -511
3	11 Bit	+ -1023
4	12 Bit	+ -2047
5	13 Bit	+ -4095
6	14 Bit	+ -8191

### Reading Quadrature Encoder Example

The following example was written using an BasicATOM Pro. Robo Claw was connected as shown in both packet serial wiring and quadrature encoder wiring diagrams.

The example will read the speed, total ticks and direction of each encoder. Connect to the program using the Basic Micro Studio terminal window set to 38400 baud. The program will display the values of each encoders current count along with each encoder status bit in binary and the direction bit. As the encoder is turned it will update the screen.

```
Encoder1 Var Long
Encoder2 Var Long
Status Var Byte
CRC Var Byte

ENABLEHSERIAL      ;used on AtomPro24 and AtomPro28. AtomPro40 and ARC-32 use EnableHSerial2

SetHSerial H38400,H8DATABITS,HNOPARITY,HLSTOPBITS

Pause 250

Hserout [128, 20, (148 & 0x7F)]; Resets encoder registers

Main
  Pause 100

ReadEncoderM1
  Hserout [128, 16]
  Hserin [Encoder1.byte3, Encoder1.Byte2, Encoder1.Byte1, Encoder1.Byte0, Status, crc]
  Serout s_out, i38400, [0,"Encoder1: ", SDEC Encoder1, 13, "Status Byte: ", BIN Status]

ReadSpeedM1
  Hserout [128, 18]
  Hserin [Encoder1.byte3, Encoder1.Byte2, Encoder1.Byte1, Encoder1.Byte0, Status, crc]
  Serout s_out, i38400, [13, 13, "Speed: ", DEC Encoder1, 13, "Direction: ", DEC Status]

ReadEncoderM2
  Hserout [128, 17]
  Hserin [Encoder2.byte3, Encoder2.Byte2, Encoder2.Byte1, Encoder2.Byte0, Status, crc]
  Serout s_out, i38400, [13, 13, "Encoder2: ", SDEC Encoder2, 13, "Status Byte: ", BIN Status]

ReadSpeedM2
  Hserout [128, 19]
  Hserin [Encoder2.byte3, Encoder2.Byte2, Encoder2.Byte1, Encoder2.Byte0, Status, crc]
  Serout s_out, i38400, [13, 13, "Speed: ", DEC Encoder2, 13, "Direction: ", DEC Status]

Goto Main
```

### Speed Controlled by Quadrature Encoders Example

The following example was written using an BasicATOM Pro. Robo Claw was connected as shown in both packet serial wiring and quadrature encoder wiring diagrams.

The example will command a 4wheel robot to move forward, backward, right turn and left turn slowly. You can change the speed by adjusting the value of Speed and Speed2 variables.

```

CMD      var byte
Speed    var long
Speed2   var long
CRC      var byte
Address  con 128

ENABLEHSERIAL ;used on AtomPro24 and AtomPro28. AtomPro40 and ARC-32 use EnableHSerial2
SetHSerial H38400,H8DATABITS,HNOPARITY,H1STOPBITS

Mixed_Forward
  CMD=37
  Speed=12000
  Speed2=12000
  CRC = (address + cmd + speed.byte3 + speed.byte2 + speed.byte1 + speed.byte0 + |
        speed2.byte3 + speed2.byte2 + speed2.byte1 + speed2.byte0)&0x7F
  hserout [address,cmd,speed.byte3,speed.byte2,speed.byte1,speed.byte0, |
        speed2.byte3,speed2.byte2,speed2.byte1,speed2.byte0,crc]
  pause 4000

Mixed_Backward
  CMD=37
  Speed=-12000
  Speed2=-12000
  CRC = (address + cmd + speed.byte3 + speed.byte2 + speed.byte1 + speed.byte0 + |
        speed2.byte3 + speed2.byte2 + speed2.byte1 + speed2.byte0)&0x7F
  hserout [address,cmd,speed.byte3,speed.byte2,speed.byte1,speed.byte0, |
        speed2.byte3,speed2.byte2,speed2.byte1,speed2.byte0,crc]
  pause 4000

Mixed_Left
  CMD=37
  Speed=-12000
  Speed2=12000
  CRC = (address + cmd + speed.byte3 + speed.byte2 + speed.byte1 + speed.byte0 + |
        speed2.byte3 + speed2.byte2 + speed2.byte1 + speed2.byte0)&0x7F
  hserout [address,cmd,speed.byte3,speed.byte2,speed.byte1,speed.byte0, |
        speed2.byte3,speed2.byte2,speed2.byte1,speed2.byte0,crc]
  pause 4000

Mixed_Right
  CMD=37
  Speed=12000
  Speed2=-12000
  CRC = (address + cmd + speed.byte3 + speed.byte2 + speed.byte1 + speed.byte0 + |
        speed2.byte3 + speed2.byte2 + speed2.byte1 + speed2.byte0)&0x7F
  hserout [address,cmd,speed.byte3,speed.byte2,speed.byte1,speed.byte0, |
        speed2.byte3,speed2.byte2,speed2.byte1,speed2.byte0,crc]
  pause 4000

Mixed_Stop
  CMD=37
  Speed=0
  Speed2=0
  CRC = (address + cmd + speed.byte3 + speed.byte2 + speed.byte1 + speed.byte0 + |
        speed2.byte3 + speed2.byte2 + speed2.byte1 + speed2.byte0)&0x7F
  hserout [address,cmd,speed.byte3,speed.byte2,speed.byte1,speed.byte0, |
        speed2.byte3,speed2.byte2,speed2.byte1,speed2.byte0,crc]

stop

```

**Electrical Characteristics**

Characteristic	Rating	Min	Typ	Max
Pulse Per Second	PPS	0		8,000,000
Main Battery (B+ / B-)	VDC	6	24	30
Logic Battery (LB+ / LB-)	VDC	6	12	17
External Current Draw (BEC)	mA		50	100
Logic Circuit	mA		90	
Motor Current Per Channel	A		5	7
I/O Voltages	VDC	4.5		5
I/O Logic	TTL	4.5		5
Tempature Range	C	-40		+125



**Warranty**

Basic Micro warrants its products against defects in material and workmanship for a period of 90 days. If a defect is discovered, Basic Micro will, at our discretion, repair, replace, or refund the purchase price of the product in question. Contact us at [support@basicmicro.com](mailto:support@basicmicro.com). No returns will be accepted without the proper authorization.

**Copyrights and Trademarks**

Copyright© 2010 by Basic Micro, Inc. All rights reserved. PICmicro® is a trademark of Microchip Technology, Inc. The Basic Atom and Basic Micro are registered trademarks of Basic Micro Inc. Other trademarks mentioned are registered trademarks of their respective holders.

**Disclaimer**

Basic Micro cannot be held responsible for any incidental, or consequential damages resulting from use of products manufactured or sold by Basic Micro or its distributors. No products from Basic Micro should be used in any medical devices and/or medical situations. No product should be used in a life support situation.

**Contacts**

Email: [sales@basicmicro.com](mailto:sales@basicmicro.com)  
Tech support: [support@basicmicro.com](mailto:support@basicmicro.com)  
Web: <http://www.basicmicro.com>

**Discussion List**

A web based discussion board is maintained at <http://www.basicmicro.com>.

**Technical Support**

Technical support is made available by sending an email to [support@basicmicro.com](mailto:support@basicmicro.com). All email will be answered within 48 hours. All general syntax and programming questions, unless deemed to be a software issue, will be referred to the on-line discussion forums.