

Apply Environmental Condition :

No.	Item	Specification
1-1	Storage Temperature Range	-20°C ~ 60°C
1-2	Operating Temperature Range	-10°C ~ 50°C
1-3	Operating Voltage Range	3. 7V~6V

Standard Test Environment :

2-1	Standard Test Environment	Every characteristic of the inspect must be normal temperature and humidity carry out the test , temperature 25±5°C and relative humidity 65±10% of judgment made in accordance with this specification standard testing conditions.
-----	---------------------------	--

Electrical Specification (Function of the Performance) :

No.	Item	4.8V	6.0V
4-1	Operating speed (at no load)	0.12 sec/60°	0.10 sec/60°
4-2	Running current (at no load)	100 mA	110 mA
4-3	Stall torque (at locked)	0.8 kg-cm	1.0 kg-cm
4-4	Stall current (at locked)	270 mA	320 mA
4-5	Idle current (at stopped)	4 mA	5 mA

Note: Item 4-2 definition is average value when the servo running with no load

Mechanical Specification :

No.	Item	Specification
5-1	Overall Dimensions	See the drawing
5-2	Limit angle	180°± 10°
5-3	Weight	4.3± 1 grams (without servo horn)
5-4	Connector wire gauge	#32 PVC
5-5	Connector wire length	100 ± 5 mm
5-6	Horn gear spline	20T/ φ 3.85
5-7	Horn type	Cross , Bar
5-8	Reduction ratio	1/378

Control Specification :

No.	Item	Specification
6-1	Control system	Pulse width modification
6-2	Amplifier type	Analog controller
6-3	Operating travel	90° (when1000→2000 μsec)
6-4	Neutral position	1500 μsec
6-5	Dead band width	7 μsec
6-6	Rotating direction	Clockwise (when1500→2000 μsec)
6-7	Pulse width range	800→2200 μsec
6-8	Maximum travel	Approx 165°(when800→2200 μsec)

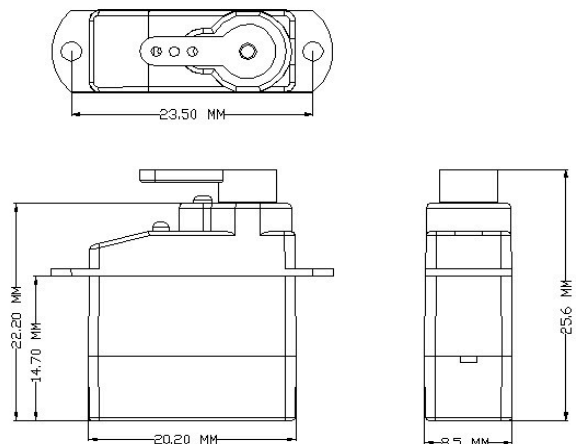

Product Name	Model No.	Version	Page
SERVO	HD-1440A	V1	1/1